

TIENet[®] 360 LaserFlow[®] Ex Velocity Sensor

Installation and Operation Guide



Part #69-4363-085

Rev. C, September 2021

Copyright © 2021. All rights reserved, Teledyne ISCO

Use and Disclosure of Data Information contained herein is classified as EAR99 under the U.S. Export Administration Regulations. Export, reexport or diversion contrary to U.S. law is prohibited.

Foreword - Water and Wastewater Products

This instruction manual is designed to help you gain a thorough understanding of the operation of the equipment. Teledyne ISCO recommends that you read this manual completely before placing the equipment in service.

Although Teledyne ISCO designs reliability into all equipment, there is always the possibility of a malfunction. This manual may help in diagnosing and repairing the malfunction.

If a problem persists, call or e-mail Teledyne ISCO technical support for assistance. Simple difficulties can often be diagnosed over the phone. For faster service, please have your serial number ready.

If it is necessary to return the equipment to the factory for service, please follow the shipping instructions provided by technical support, including the use of the Return Merchandise Authorization (RMA) specified. Be sure to include a note describing the malfunction. This will aid in the prompt repair and return of the equipment. **No item may be returned for service without a Return Material Authorization (RMA) number issued by Teledyne.**

Teledyne ISCO welcomes suggestions that would improve the information presented in this manual or enhance the operation of the equipment itself.

Teledyne ISCO is continually improving its products and reserves the right to change product specifications, replacement parts, schematics, and instructions without notice.

Contact Information

Customer Service

Phone: (800) 228-4373 (USA, Canada, Mexico)
(402) 464-0231 (Outside North America)

Fax: (402) 465-3022

Email: isco.orders@teledyne.com

Technical Support

Phone: Toll Free (866) 298-6174 (Samplers and flowmeters)

Email: iscowatersupport@Teledyne.com

Return equipment to: 4700 Superior Street, Lincoln, NE 68504-1398

Other Correspondence

Mail to: P.O. Box 82531, Lincoln, NE 68501-2531

Warranty and Operation Manuals can be found on our website at:

www.teledyneisco.com

General Warnings

 **WARNING**

Caution: Use of controls or adjustments or performance of procedures other than those specified herein may result in hazardous radiation exposure.

Wavelength: 655 nm

Maximum Power: 5 mW

Before installing, operating, or maintaining this equipment, it is imperative that all hazards and preventive measures are fully understood. While specific hazards may vary according to location and application, take heed of the following general warnings:

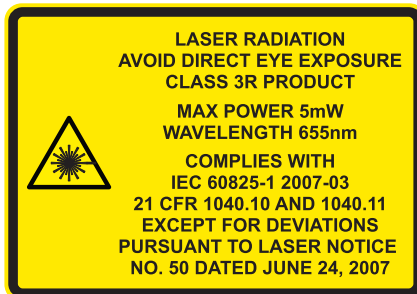

 **WARNING**

Avoid hazardous practices! If you use this instrument in any way not specified in this manual, the protection provided by the instrument may be impaired.

 **DANGER**

The LaserFlow Ex **MUST** be installed in accordance with control drawing, in Figure 2-1 thru Figure 2-3 in this manual, and in accordance with the requirements of the authority that has jurisdiction for the installation of equipment in hazardous areas at your specific installation site.

The certified control drawing details the only approved method of installing the LaserFlow Ex. Where specific ISCO part numbers appear, they represent the only approved equipment certified to be used with the LaserFlow Ex. Any equipment substitutions or installations not specifically detailed on the control drawing will automatically void the intrinsically safe certification of the LaserFlow Ex and could result in fire or explosion!

Hazard Severity Levels

This manual applies *Hazard Severity Levels* to the safety alerts, These three levels are described in the sample alerts below.

 **CAUTION**

Cautions identify a potential hazard, which if not avoided, may result in minor or moderate injury. This category can also warn you of unsafe practices, or conditions that may cause property damage.

 **WARNING**









Warnings identify a potentially hazardous condition, which if not avoided, could result in death or serious injury.

 **DANGER**

DANGER – limited to the most extreme situations to identify an imminent hazard, which if not avoided, will result in death or serious injury.

Hazard Symbols

The equipment and this manual use symbols used to warn of hazards. The symbols are explained below.

Hazard Symbols	
Warnings and Cautions	
	The exclamation point within the triangle is a warning sign alerting you of important instructions in the instrument's technical reference manual.
	The lightning flash and arrowhead within the triangle is a warning sign alerting you of "dangerous voltage" inside the product.
Symboles de sécurité	
	Ce symbole signale l'existence d'instructions importantes relatives au produit dans ce manuel.
	Ce symbole signale la présence d'un danger d'électocution.
Warnungen und Vorsichtshinweise	
	Das Ausrufezeichen in Dreieck ist ein Warnzeichen, das Sie darauf aufmerksam macht, daß wichtige Anleitungen zu diesem Handbuch gehören.
	Der gepfeilte Blitz im Dreieck ist ein Warnzeichen, das Sie vor "gefährlichen Spannungen" im Inneren des Produkts warnt.
Advertencias y Precauciones	
	Esta señal le advierte sobre la importancia de las instrucciones del manual que acompañan a este producto.
	Esta señal alerta sobre la presencia de alto voltaje en el interior del producto.

TIENet® 360 LaserFlow Ex® Velocity Sensor

Table of Contents

Section 1 Introduction

1.1 LaserFlow Ex.	1-1
1.2 Design of LaserFlow Ex	1-2
1.2.1 Measurement Technology	1-2
1.2.2 Cabling	1-2
1.3 Operation	1-2
1.4 Technical Specifications	1-3
1.5 Accessories	1-5
1.5.1 Ordering Information	1-5
1.6 Unpacking Instructions	1-6
1.6.1 Protective Window Cap	1-6

Section 2 Preparation and Installation

2.1 Safety	2-1
2.1.1 Site Conditions	2-1
2.1.2 Installation in Hazardous Locations	2-2
2.1.3 Important Information Regarding “X” Marking	2-2
2.1.4 Electrical Requirements	2-3
2.1.5 Ambient Environment	2-3
2.2 Sensor Installation Considerations	2-6
2.2.1 Ultrasonic Beam Angle	2-6
2.2.2 High Water Levels	2-6
2.2.3 Submersion and Fouling	2-6
2.2.4 Humidity	2-7
2.2.5 Surface	2-7
2.2.6 Temperature	2-7
2.2.7 Waves	2-7
2.2.8 Wind	2-7
2.3 Installation Checklist	2-7
2.4 Connecting the Cable	2-7
2.4.1 Cable Connection: TIENet Barrier	2-7
2.4.2 Cable Connection: Signature Flowmeter	2-8
2.4.3 Remote Ultrasonic Cable Connection: 310 Ultrasonic Sensor	2-13
2.5 Sensor Installation Tools and Requirements.	2-14
2.5.1 Tools Required	2-14
2.5.2 Sensor and Mounting Equipment Dimensions	2-14
2.5.3 Sensor Positioning and Requirements	2-16
2.6 Wall Mounting Kit	2-18
2.6.1 Wall Mount Installation	2-19
2.7 Optional Sunshade	2-23
2.8 Remote TIENet Model 310 Ultrasonic Level Sensor.	2-24

Section 3 Setup with Signature® flowmeter

3.1	Configuring the System	3-1
3.1.1	Updating the Device List	3-1
3.2	Measurement Setup	3-4
3.2.1	360 Level	3-5
3.2.2	360 Velocity	3-5
3.2.3	LaserFlow Ex Velocity Advanced Settings	3-5
3.3	360 Velocity Grid	3-9
3.4	Sensor Positioning and Adjustment	3-10
3.4.1	Centering the LaserFlow Ex Sensor	3-10
3.4.2	Laser Velocity Measurement Point Selection	3-10
3.4.3	Ultrasonic Level Adjustment	3-11
3.5	Contact Teledyne ISCO	3-12

Section 4 Setup with 2160 LaserFlow Module

4.1	Activating Connected Sensors	4-1
4.2	Measurement Display and Settings	4-3
4.2.1	360 Level	4-5
4.2.2	360 Velocity	4-7
4.2.3	Advanced Settings	4-8
4.3	Sensor Positioning and Adjustment	4-14
4.3.1	Centering the LaserFlow Ex Sensor	4-14
4.3.2	Laser Velocity Measurement Point Selection	4-15

Section 5 Maintenance and Optional Kits

5.1	Maintenance	5-1
5.2	Firmware Updates	5-2
5.2.1	With Signature flowmeter	5-2
5.2.2	With 2160 LaserFlow Module	5-2
5.3	Cleaning the Sensor Housing	5-2
5.4	Accessing the LaserFlow Ex's Nose Piece	5-2
5.4.1	Removing the Nose Piece	5-3
5.4.2	Replacing the Nose Piece	5-4
5.5	Velocity Readings and the Laser Window	5-5
5.6	Cleaning the Laser Window	5-5
5.7	Installing the Remote TIENet 310 Ultrasonic Level Sensor	5-6

Appendix A Replacement Parts

A.1	Replacement Parts	A-1
A.2	LaserFlow Ex Sensor	A-2
A.3	Wall Mounting Hardware	A-4

Appendix B Installation Checklist

B.1	Introduction	B-1
B.2	Equipment and Recommended Tools	B-2
B.3	Site Information	B-2
B.4	Recommended Essential Parameters	B-5
B.5	Site Conditions	B-5
B.6	Sensor Positioning	B-8

Appendix C Velocity Error Codes

C.1 Introduction	C-1
C.2 Importing Data Dump (.ddp) Files (Signature Only)	C-1
C.3 Viewing Velocity Error Codes in Flowlink	C-3

Appendix D Material Safety Data Sheets

List of Figures

1-1 Basic LaserFlow Ex system (showing both AC and battery-powered options) . . .	1-1
1-2 Remove protective window cap before installation	1-6
2-1 Wiring diagram	2-3
2-2 LaserFlow Ex control drawing	2-4
2-3 LaserFlow Ex control drawing	2-5
2-4 Ultrasonic level sensor beam angle	2-6
2-5 Signature connected with the TIENet Barrier	2-8
2-6 TIENet Device terminal strips	2-9
2-7 Installing cable with a cord-grip fitting	2-9
2-8 TIENet Device terminal connections	2-10
2-9 Attach wired terminal strip to case board socket	2-11
2-10 Insert the cable reference tubing into the case board reference port	2-11
2-11 Position and secure the cable	2-12
2-12 Preparing the LaserFlow Ex connector receptacle	2-13
2-13 Secure caps and connect 310 ultrasonic plug to LaserFlow Ex	2-13
2-14 Overall dimensions including wall mounting hardware (part 1)	2-14
2-15 Overall dimensions including wall mounting hardware (part 2)	2-15
2-16 Typical manhole installation	2-17
2-17 Wall mounting kit (Numbers correspond with Table 2-1)	2-18
2-18 Wall Mount: Vertical clamp and vertical clamp with tube coupler inserted . . .	2-19
2-19 Wall Mount: Sensor carrier installed on tube coupler	2-20
2-20 Wall Mount: Place the sensor on the carrier	2-21
2-21 Mounting the sunshade	2-23
2-22 Mounted sunshade	2-24
3-1 Character grid	3-2
3-2 Menu Tree: LaserFlow Ex Configuration	3-3
3-3 Measurement Setup: Sensor input settings	3-4
3-4 Blanking distance for LaserFlow Ex with built-in sensor or with remote ultrasonic sensor	3-5
3-5 Measurement setup: Advanced settings for LaserFlow Ex sensor	3-8
3-6 360 Velocity grid	3-9
3-7 Selection of velocity measurement points	3-11
3-8 Ultrasonic level adjustment	3-12
4-1 Activate connected sensors in Flowlink	4-1
4-2 Activating connected sensors in Flowlink	4-2
4-3 Measurements tab: Displays real-time measurements	4-3
4-4 Drop down list of measurements for 2160 Module	4-4
4-5 360 Level Measurement tab in Flowlink	4-5
4-6 Blanking distance for LaserFlow Ex with built-in sensor or 310 remote ultrasonic sensor	4-6
4-7 360 Velocity Measurement tab in Flowlink	4-7
4-8 360 Velocity Tab: Advanced settings	4-8
4-9 Remote distance measurement with the 310 remote ultrasonic sensor	4-10
4-10 Remote distance measurement with the 310 remote ultrasonic sensor and horizon- tal sensor mount bracket	4-11

4-11	LaserFlow Ex placement using Parallel to Channel Slope option	4-12
4-12	LaserFlow Ex placement using Slope Percentage option	4-13
4-13	Selection of velocity measurement points	4-15
5-1	Remove large screws and nose piece (3 on each side)	5-3
5-2	Location and orientation of cross-pins for mounting block installation	5-4
5-3	Cleaning the laser window: Moisten Kimwipe tissue w/ Rain-X	5-6
B-1	Do not install LaserFlow Ex with built-in sensor in a free-flowing outfall or in a drop manhole.	B-5
B-2	Correct setup when using the LaserFlow Ex module with remote ultrasonic sensor and horizontal mount bracket	B-6
B-3	Placement of LaserFlow Ex with built-in sensor	B-6
B-4	Placement of LaserFlow Ex with remote ultrasonic sensor	B-7
C-1	Signature flow data: Selecting the .ddp file(s)	C-2
C-2	Signature flow data: Importing the .ddp file	C-2
C-3	Identifying error codes in the 360 Velocity data set	C-3

TIENet® 360 LaserFlow Ex® Velocity Sensor

Section 1 Introduction

1.1 LaserFlow Ex

The TIENet 360 LaserFlow Ex sensor is an Area Velocity flow measurement device that remotely measures flow in open channels with non-contact Laser Doppler Velocity Sensing and non-contact Ultrasonic Level Sensing technologies. The sensor uses advanced technology to measure velocity with a laser beam at single or multiple points below the surface of the water stream.

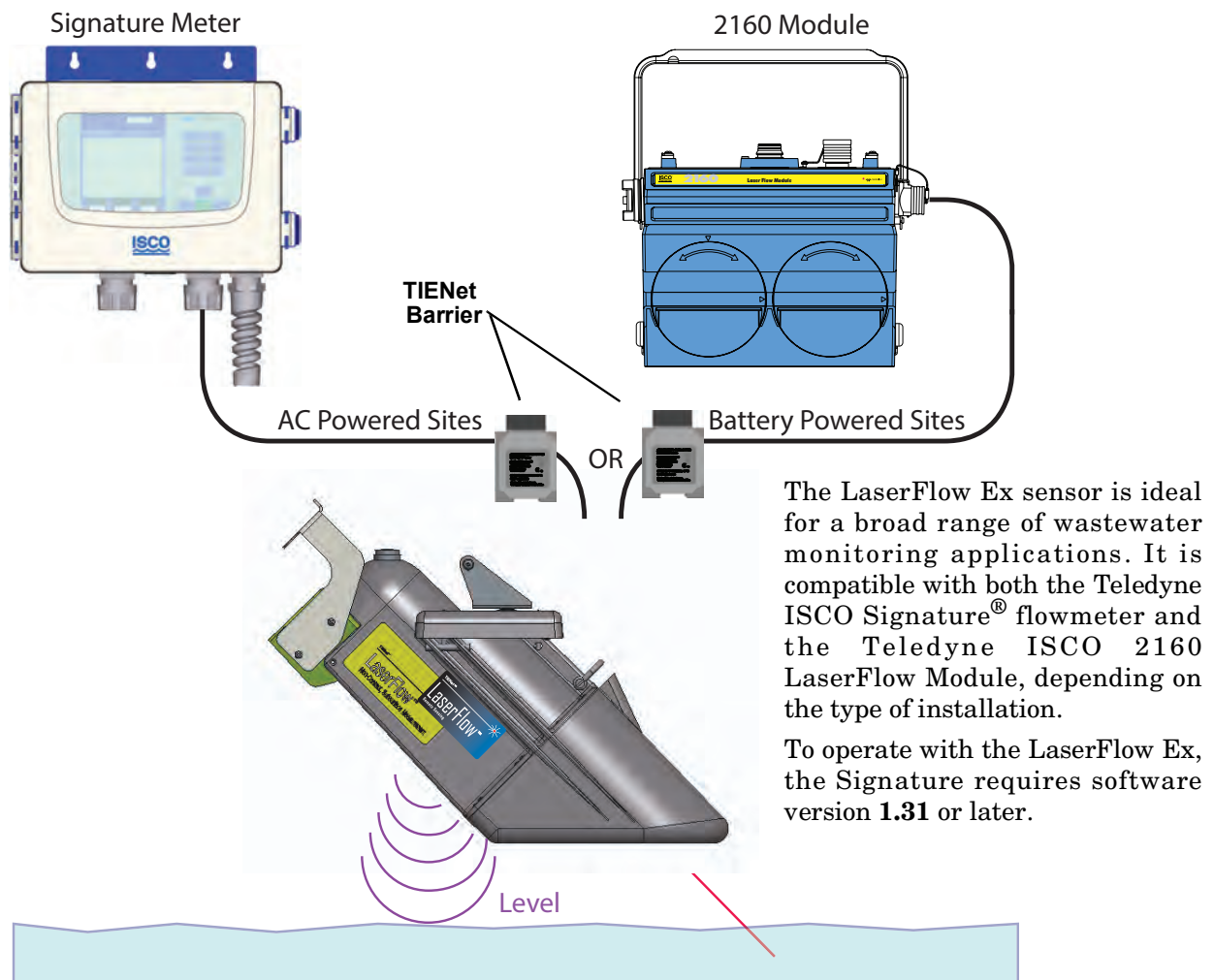

The LaserFlow Ex sensor is ideal for a broad range of wastewater monitoring applications. It is compatible with both the Teledyne ISCO Signature® flowmeter and the Teledyne ISCO 2160 LaserFlow Module, depending on the type of installation.

To operate with the LaserFlow Ex, the Signature requires software version **1.31** or later.

Figure 1-1 Basic LaserFlow Ex system (showing both AC and battery-powered options)

1.2 Design of LaserFlow Ex

The LaserFlow Ex sensor consists of a housing with two measurement technologies working together.

1.2.1 Measurement Technology

The **laser velocimeter** has a laser diode that serves as both transmitter and receiver of a laser light beam. The Doppler-shifted signal frequency is used to determine flow stream velocity.

The **ultrasonic level transducer** determines the stream's level by emitting an ultrasonic pulse and measuring the time it takes for the echo to return from the stream's surface. The transducer is both pulse transmitter and echo receiver.

1.2.2 Cabling

The LaserFlow Ex sensor is available with a 10m or 23m standard length cable. Custom cable lengths are also available up to 108 feet.

The maximum recommended distance between the TIENet Barrier and the LaserFlow Ex is 33 meters.

1.3 Operation

The **laser velocimeter** uses a laser beam to generate a source frequency light, which is focused at points below the surface of the flow stream. The light is scattered back to the laser. The returned light is frequency shifted due to the Doppler effect. The lens that focused the laser light below the surface of the flow stream focuses the returned light back into the laser. The source light and shifted light frequencies are separated to determine a Doppler shift, which is then used to calculate flow stream velocity.

The **ultrasonic level transducer** emits multiple ultrasonic pulses per second. Between pulses, the transducer switches from transmitter to receiver. When the transducer receives the echo from the water's surface, the sound energy is converted into an electrical signal. The signal is then amplified and processed by the flowmeter into an echo-received signal. The time between the transmitted pulse and the echo-received signal is proportional to the distance between the transducer and the liquid surface, which is then used to calculate level. Because the speed of the pulse through air varies with temperature, compensation is built-in. A temperature sensor inside the level transducer measures ambient temperature. The microprocessor program automatically compensates for speed-of-sound changes caused by air-temperature changes.

The LaserFlow Ex operates with no deadband from the measurement point for both level and velocity measurement.

1.4 Technical Specifications

Table 1-1 provides technical specifications for the LaserFlow Ex.

Table 1-1 LaserFlow Ex Sensor Specifications^a	
Size (H x W x D)	18.0 x 9.5 x 23.5 in 45.7 x 24.1 x 59.7 c,
Cable Lengths ^b	10 or 23 m 32.8 or 75.5 ft NOTE: 33 m max from LaserFlow Ex to TIENet barrier.
Weight	24.8 lbs (11.25 kg)
Materials	Conductive Carbon Filled ABS Plastic, SST, Conductive Kynar®, Anodized Aluminum, UV Rated PVC
Enclosure (self-certified)	IP68 (Submerged @ 2 m depth for 72 hrs)
Certification	CE EN61326; FDA CDRH 21CFR1040; IEC 60825-1 Class 1, Div 1, Gr. C-D, T4, Ex ia Class1, Zone 0, Ex/AEx ia op is IIB T4 Ga Ex ia op is IIB T4 Ga IECEX II 1 G Ex ia op is IIB T4 Ga -10 °C < Tamb < +60 °C
Laser Class	Class 3R
Laser Wavelength	655 nm
Laser Exit Angle	45° ±3°
Input Voltage (Operating)	10 to 13VDC Recommend; 8VDC Minimum
Input Power (Operating)	1.6W/200mA
Electrical Connections	Signature flowmeter, Screw Terminal, 2160 LaserFlow Module, TIENet Plug, TIENet Barrier
Temperature Range	Operating: 14 to 140 °F (-10 to 60 °C) Storage: -40 to 140 °F (-40 to 60 °C)
Flow Accuracy	±4% of Reading (Typical under less than half pipe flow conditions.)
Velocity Measurement	
Technology	Non-Contact, Subsurface Laser Doppler Velocity (U.S. patent 8,339,584 and patents pending)
Measurement Range	0.5 ft/s to 15 ft/s 0.15 to + 4.6 m/sec
Number of velocity readings per measurement	1 to 3 (selectable measurement points)
Maximum distance: liquid surface to bottom of sensor	3m (10 ft)
Minimum depth for velocity measurement	0.01m (0.5 in)
Minimum Velocity	0.5 ft/s (0.15 m/s)
Deadband	Zero deadband from bottom of LaserFlow Ex sensor ^d
Accuracy in full pipe or lower flow conditions	±0.5% of reading ±0.03 m/s (0.1 ft/s)

Table 1-1 LaserFlow Ex Sensor Specifications^a (Continued)

Level Measurement	
Technology	Non-Contact Ultrasonic Signal
Measurement Range	0 to 3 m (0 to 10 ft) from measurement point
Accuracy @ 22 °C	±0.006m (0.02 ft) at < 1ft level change; ±0.012m (0.04 ft) at > 1ft level change
Ultrasonic Temperature Coefficient	± 0.0002 x D (m) per °C (± 0.00011 x D (ft) per °F) (Where D is the distance from transducer to liquid surface)
Ultrasonic Beam Angle	10° (5° from center line)
Ultrasonic Signal	50KHz
Deadband	Zero deadband from bottom of LaserFlow Ex sensor

- a. All specifications are subject to change without notice.
- b. Custom cable lengths also available.
- c. Kynar® is a registered trademark of Arkema, Inc.
- d. Deadband for 310 remote ultrasonic sensor varies due to the type of mounting hardware.

1.5 Accessories

Accessories used in sensor installation are briefly described below. Refer to the next section for ordering information.

1.5.1 Ordering Information

Options and accessories can be purchased by contacting Teledyne ISCO's Customer Service Department.

Teledyne ISCO

Customer Service Dept.

P.O. Box 82531

Lincoln, NE 68501 USA

Phone: 800 228-4373

FAX: 402 465-3022

E-mail: IscoInfo@teledyne.com

Cord grip fitting, 3/4" NPT, for TIENet cable	209-0073-12
Signature flowmeter Exterior desiccator (required for use with 330 and 350 TIENet devices).....	60-4304-092
Silica gel desiccant, 1.5-lb container	60-2004-233
Permanent Wall Mounting Hardware Kit	60-4364-003

Refer to Section 2.6.1 *Wall Mount Installation* for additional information.

<input checked="" type="checkbox"/> Note

Teledyne ISCO uses FreeRTOS version 5.4.2 in its TIENet devices. In accordance with the FreeRTOS license, FreeRTOS source code is available on request. For more information, visit www.FreeRTOS.org.

1.6 Unpacking Instructions

When the system arrives, inspect the outside packing for any damage. Then carefully inspect the contents for damage. If there is damage, contact the delivery company and Teledyne ISCO (or its agent) immediately.

WARNING

If there is any evidence that any items may have been damaged in shipping, do not attempt to install the unit. Please contact Teledyne ISCO (or its agent) for assistance.

When you unpack the system, check the items against the packing list. If any parts are missing, contact the delivery company and Teledyne ISCO's Customer Service Department. When you report missing part(s), please indicate them by part number. In addition to the main packing list, there may be other packing lists for various sub-components.

It is recommended that you retain the shipping cartons as they can be used to ship the unit in the event that it is necessary to transport the system. Please complete the registration card and return it to Teledyne ISCO.

1.6.1 Protective Window Cap

Leave the protective window cap in place until the sensor is ready to be installed.

Before installation, remove the cap. The sensor will not be able to measure velocity with the cap in place. Retain the cap for use during cleaning, storage, or shipment, to protect the laser window from damage.

CAUTION

Be sure the protective window cap is installed during cleaning, storage, or shipment.



Figure 1-2 Remove protective window cap before installation

TIENet® 360 LaserFlow Ex® Velocity Sensor

Section 2 Preparation and Installation

2.1 Safety

Before installing, operating, or maintaining this equipment, it is imperative that all hazards and preventive measures are fully understood.

2.1.1 Site Conditions

Components are often installed in confined spaces. Some examples of confined spaces include manholes, pipelines, digesters, and storage tanks. These spaces may become hazardous environments that can prove fatal for those unprepared. These spaces are governed by OSHA 1910.146 and require a permit before entering.

WARNING

The installation and use of this product may subject you to hazardous working conditions that can cause you serious or fatal injuries. Take any necessary precautions before entering a worksite. Install and operate this product in accordance with all applicable safety and health regulations, and local ordinances.

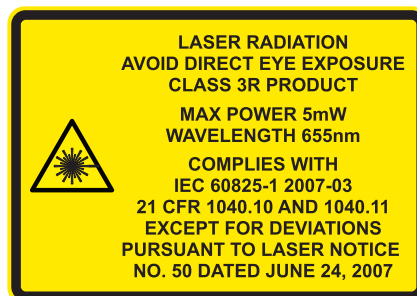

2.1.2 Installation in Hazardous Locations

Read all labels carefully before installing the equipment!

The Laserflow Ex device is ATEX-approved for use in potentially explosive atmospheres when specific conditions are met, as described in this section in reference to “X” Marking.

The LaserFlow Ex is Group II, Category 1G equipment for use in gas hazard zones 0, 1, and 2 (European standards), or Class I Division 1 (North American standards).

The braid-drain lead depicted in Figure 2-1 is normally bonded to earth through the Signature connector case terminals or conduit. The mounting bracket used with the LaserFlow Ex should be installed such that there is a conductive path from the LaserFlow Ex case to earth. The internal circuitry utilizes a ground connection to the conductive case.

Installation must be performed only by trained, qualified personnel.

Barriers or isolators required for certifiable safe installation are the responsibility of the user. Refer to the control drawings provided in Figures 2-9.

 **CAUTION**

Use only non-sparking metal for US mounting hardware. Check with local authorities.

 **WARNING**

The mounting bracket is a potential isolated charge carrier. For classified hazardous locations, refer to section 12.2.4 and local authorities for installation requirements.

 **WARNING**

Do not coil the sensor cable; this will form an inductor and create a hazard. The cable should be kept as short as is practical. If necessary, use a serpentine loop (see figure at left) instead.

Serpentine loop

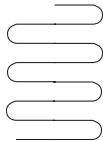

2.1.3 Important Information Regarding “X” Marking

The ATEX labeling on the serial tag of the LaserFlow Ex device includes a number ending in “X.” The X marking indicates that there are specific conditions that must be met in order for the equipment to comply with intrinsic safety requirements. Refer to Figure 2-1 on the following page.

These specific conditions are as follows:

- The cable must be terminated in a manner suitable for the zone of installation.
- The physical spacing between the exposed ends of each insulated wire lead, and earth ground and other IS circuits, must be such that the equipment is isolated up to 500V, and to 1500V for non-IS circuitry.

2.1.4 Electrical Requirements

Always refer to the electrical values listed at the bottom of the LaserFlow Ex serial tag when connecting associated apparatus (i.e., power supply, network interface, etc.).

This labeling indicates the maximum input voltage (U_i), maximum input current (I_i), and maximum power (P_i) that can be present at the specified terminals without invalidating intrinsic safety.

The power supply parameter allowances *must exceed* maximum internal capacitance (C_i) and the maximum internal inductance-to-resistance ratio (L_i/R_i) of the LaserFlow Ex device and cable. These parameters are established on the control drawing Figure 2-1.

2.1.5 Ambient Environment

Installation in designated hazardous areas must fall within the temperature range of -10 to $+60^\circ\text{C}$, as specified on the serial tag labeling.

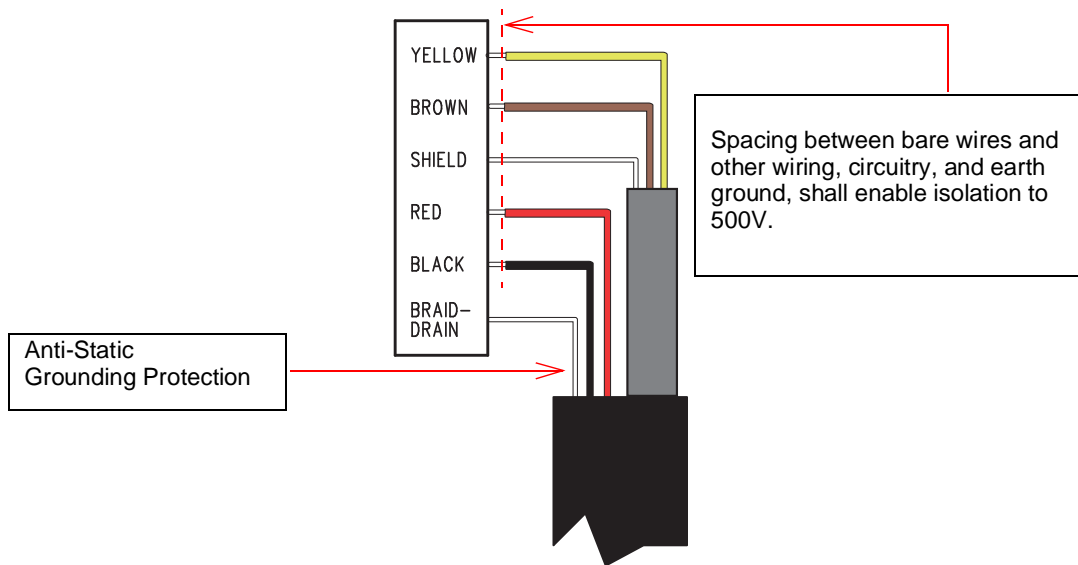

Figure 2-1 Wiring diagram

TIENet® 360 LaserFlow Ex® Velocity Sensor Section 2 Preparation and Installation

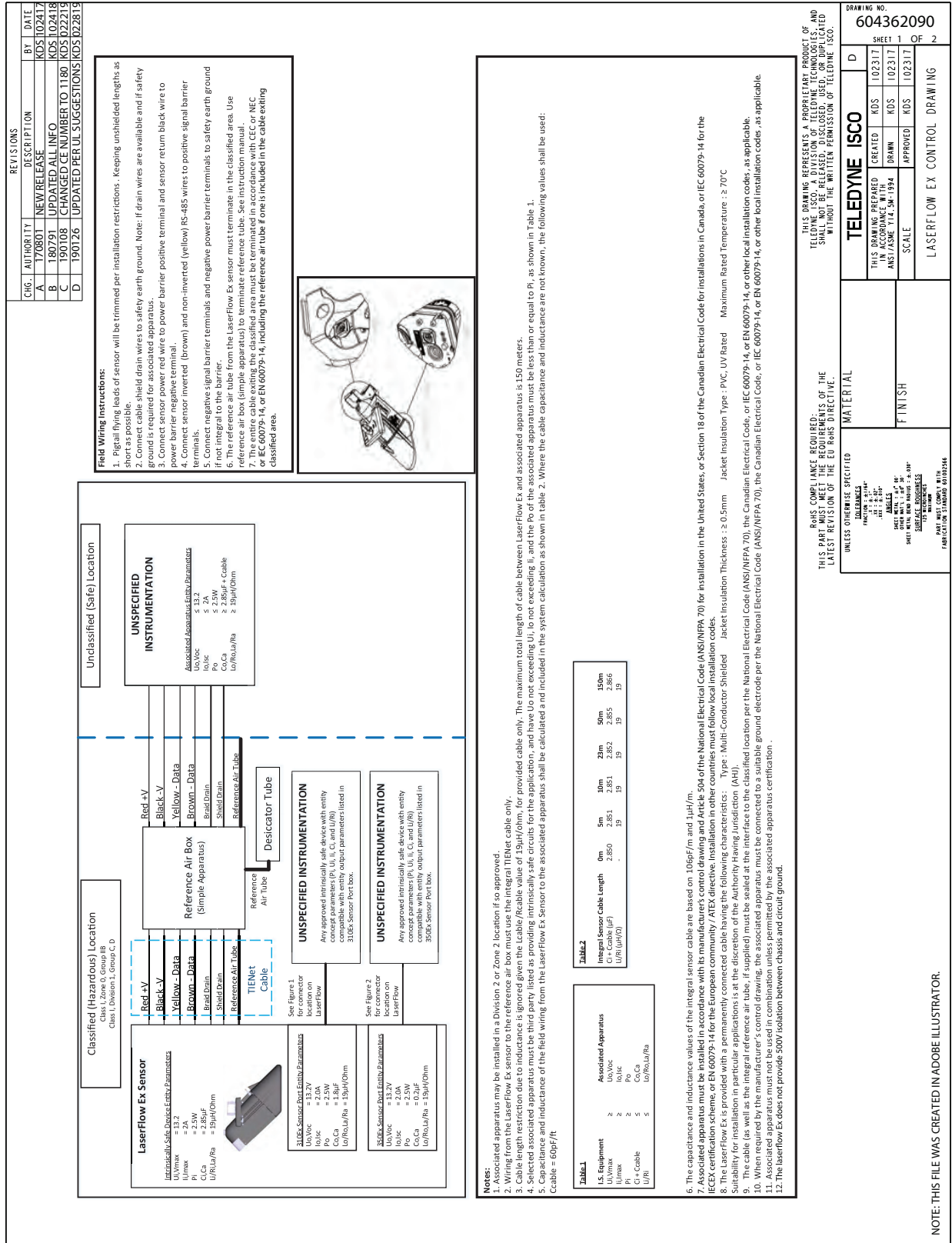

Figure 2-2 LaserFlow Ex control drawing

2.2 Sensor Installation Considerations

Measurement accuracy can be affected by a number of site factors that should be taken into consideration when selecting the location for the sensor.

These factors may affect the laser velocity or the ultrasonic level, or both.

If the laser velocimeter or ultrasonic transducer cannot obtain a valid reading at any measurement point, an asterisk (*) will appear next to the displayed reading, indicating there is an error.

2.2.1 Ultrasonic Beam Angle

The ultrasonic level transducer has a 10° beam angle (5° from center line), forming a cone in which the apex is the transducer. The transducer can only detect surfaces within this cone.

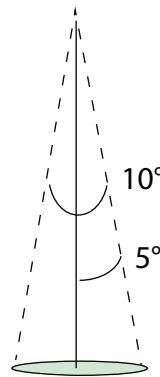

Figure 2-4 Ultrasonic level sensor beam angle

The beam widens as distance to the flow stream increases. If the beam is too wide, the sensor may pick up signals from unwanted surfaces, such as the walls of the channel. Narrow channels can result in false echoes and incorrect level readings from the walls and sides of the channel. False Echo's can be minimized by using adjusting the minimum and maximum ultrasonic blanking distance.

2.2.2 High Water Levels

In manhole installations where the level may exceed one-half of the full pipe, but less than full pipe, mount the sensor as near as possible to the midpoint between the entrance and exit to measure over the least turbulent flow.

Where the level may exceed full pipe, the sensor should be mounted as close as possible to the flow entrance with the bottom of the sensor level with the top inner surface of the inlet pipe.

2.2.3 Submersion and Fouling

Fouling by grease or solids can cause the LaserFlow Ex sensor to malfunction. The LaserFlow Ex is sealed, so unless it is exposed to corrosive substances, submersion of 2 meters, up to 72 hours will not harm it. Upon retrieval from submersion, ensure that the surfaces of the laser window and ultrasonic sensor are clean.

Cleaning instructions are provided in Section 5.

- 2.2.4 Humidity** Conditions of extremely high or low humidity affect the speed of sound. To minimize this effect place the sensor as close as possible to the flow stream.
- 2.2.5 Surface** Solids, foam, oil, and turbulence can absorb or scatter the ultrasonic and laser signals, causing errors in detection. Foam or oil on the surface of the stream can also produce false level readings.
- 2.2.6 Temperature** Changes in ambient temperature significantly affect the velocity of sound. If ambient temperature changes rapidly, there may be a delay before the temperature sensor of the ultrasonic transducer can activate temperature compensation. Compensation is based on sensor temperature, to minimize the effect of air temperature gradients place the sensor as close as possible to the flow stream.

 **Note**

If the sensor is installed outdoors in direct sunlight, use a sunshade to prevent heating of the sensor housing.

- 2.2.7 Waves** Waves on the surface of the flow stream can scatter the ultrasonic signal, causing erroneous readings or total loss of signal. The flowmeter software rejects occasional readings that deviate substantially from normal.
- 2.2.8 Wind** Strong winds can reduce the strength of the ultrasonic return echo. To minimise effect, place the ultrasonic level measurement as close as possible to the flow stream.

- 2.3 Installation Checklist** Prior to installing the system, ensure that you have all supplies and site information readily available.
- To assist you in this preparation, this manual includes the *Installation Checklist*, page B-1. Teledyne ISCO recommends that you print this appendix and fill in the relevant information.

- 2.4 Connecting the Cable** The LaserFlow Ex cable will have one of two different connector types:

- Unterminated for the TIENet Barrier

 **Note**

The TIENet Barrier connects to the Signature and the 2160 module.

- 2.4.1 Cable Connection: TIENet Barrier** LaserFlow Ex must connect to the TIENet Barrier. For more information, see the *TIENet Barrier Installation Guide*.

**2.4.2 Cable Connection:
 Signature Flowmeter**

Connect the LaserFlow Ex sensor to the Signature through the TIENet Barrier.

Refer to the Signature flowmeter manual for instructions on accessing the instrument's interior components.

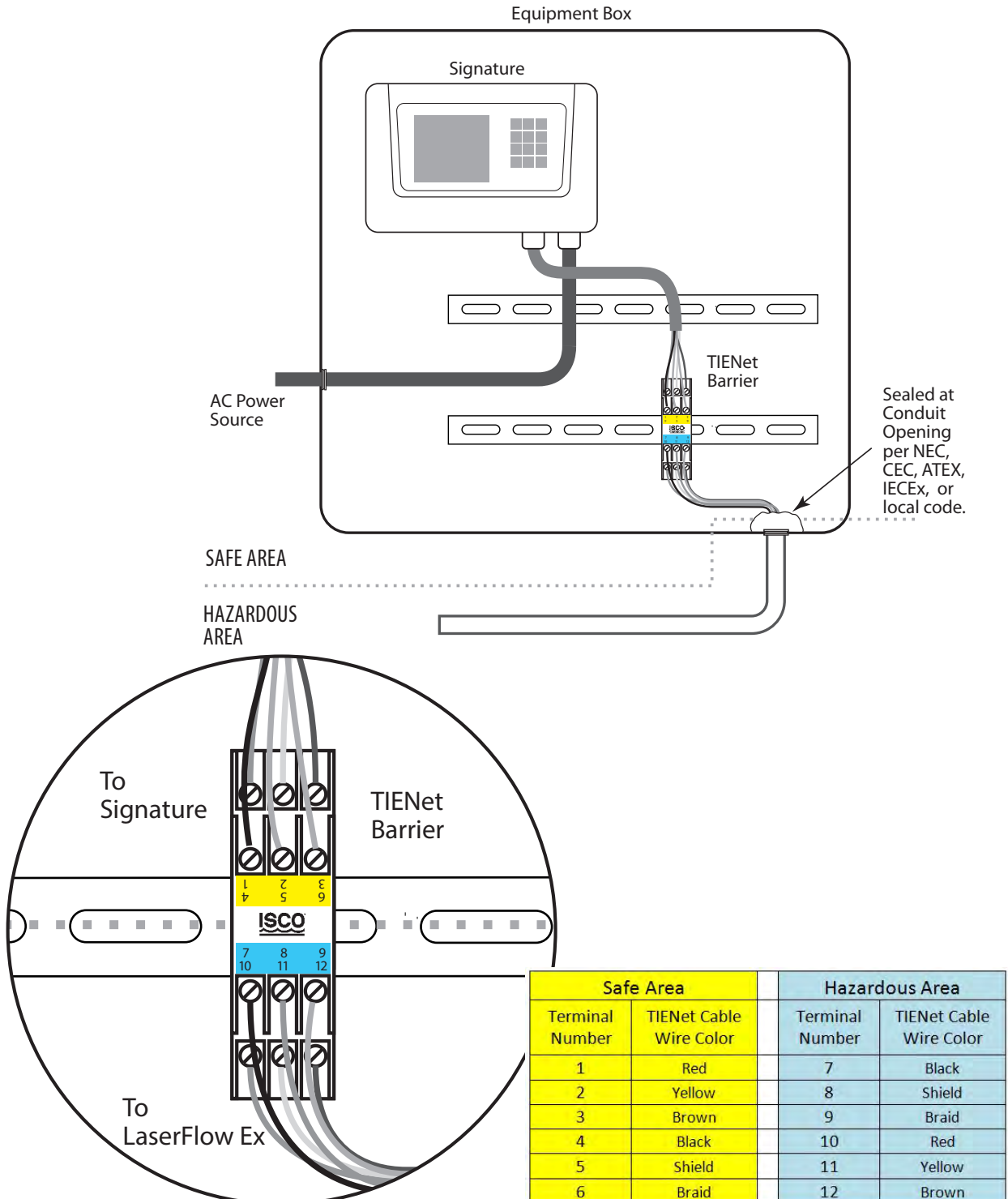

Figure 2-5 Signature connected with the TIENet Barrier

⚠ WARNING

Before proceeding, ensure that the flowmeter has been disconnected from mains power.

✓ Note

The following steps include instructions for installing cord-grip fittings. Some applications may use user-supplied $\frac{3}{4}$ " ID conduit for cable routing.

1. Remove one of the 6-position plug-in terminal strip connectors from the case board.

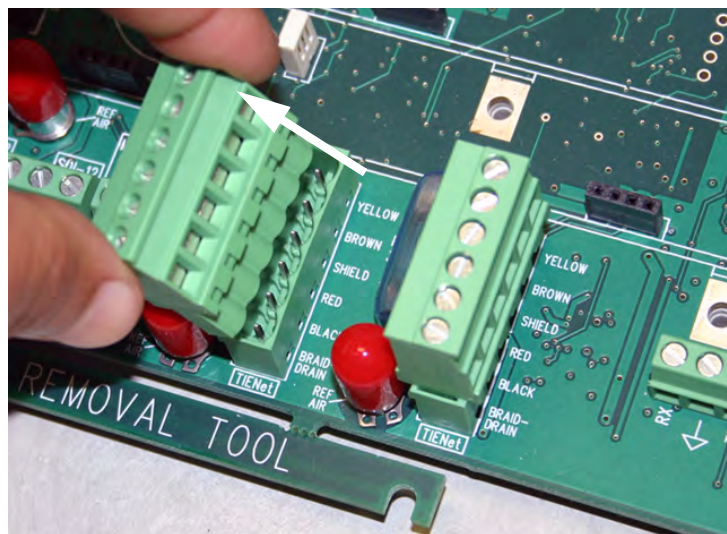

Figure 2-6 TIENet Device terminal strips

2. If using a cord-grip fitting, install the cable nut in the appropriate opening on the bottom of the Signature enclosure, securing it to the wall with the lock nut (concave side facing wall).

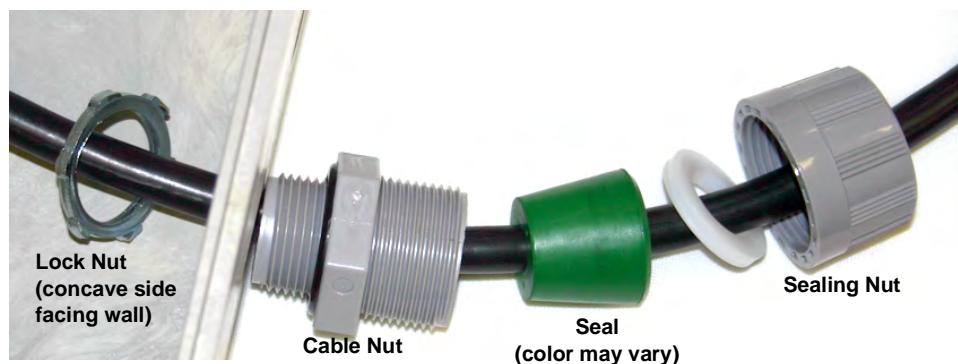

Figure 2-7 Installing cable with a cord-grip fitting

3. Feed the TIENet device cable end through the sealing nut and seal and through the cable nut. Lightly tighten the sealing nut, just enough to hold the cable in place while installing the connector.
4. Attach the wire ends to the terminal strip as shown in Figure 2-8), then press the terminal strip back down into its socket on the case board, as shown in Figure 2-9, ensuring no wire connections are strained. Gently tug each wire when finished, to verify secure connection to the screw terminals.

Note

The SHIELD wire is the bare drain emerging from the foil shield around the YELLOW and BROWN wires. The BRAID-DRAIN wire is the bare drain emerging from the surrounding braided shield inside the cable jacket. It is not necessary to prevent the two braids from coming into contact with each other.

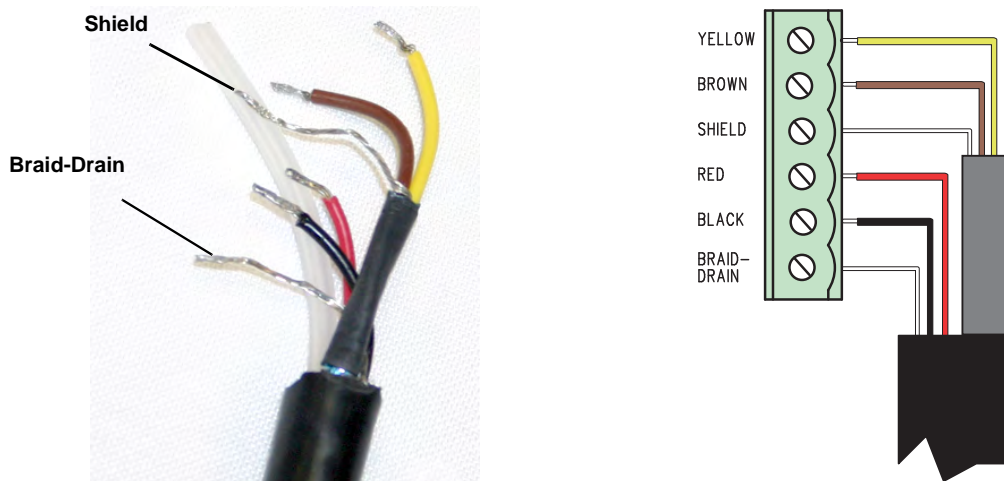

Figure 2-8 TIENet Device terminal connections

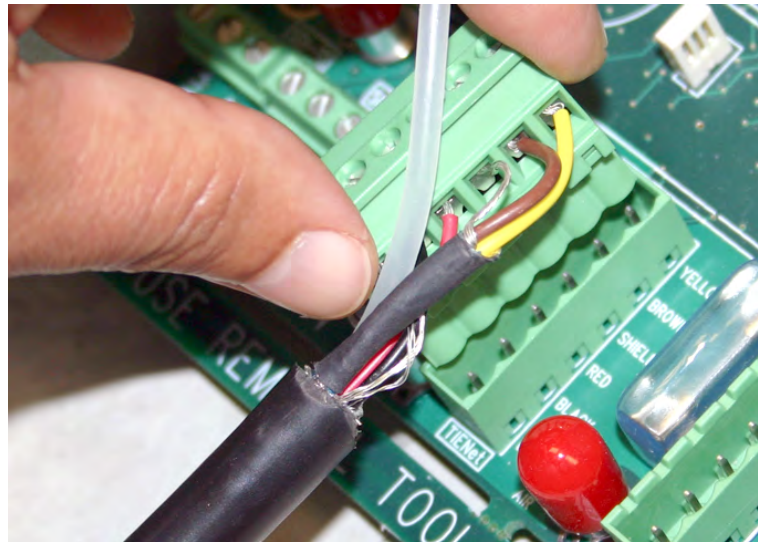

Figure 2-9 Attach wired terminal strip to case board socket

5. (Optional) Insert the reference tubing into the REF AIR port on the case board, pushing it down inside the silicon tubing. **Take precaution not to bend or kink the reference tubing.**

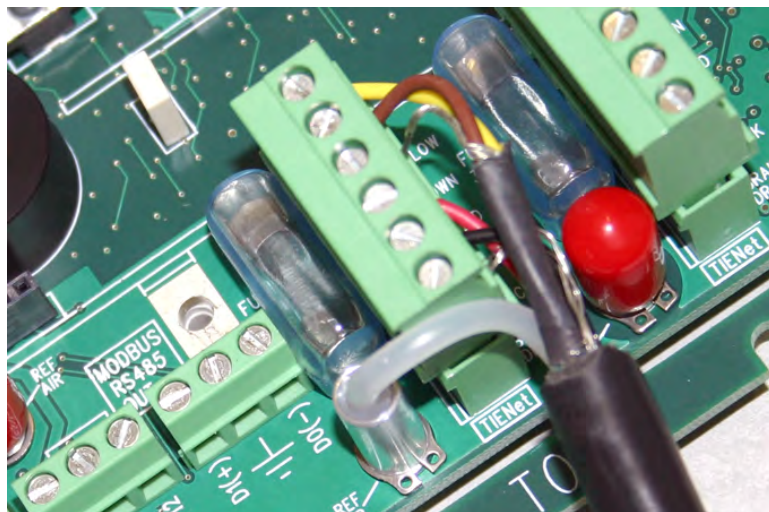

Figure 2-10 Insert the cable reference tubing into the case board reference port

6. Gently tug the cable downward to remove any slack within the enclosure, taking care not to put any stress on the connections.

7. Tighten the cord grip sealing nut (Figure 2-11).

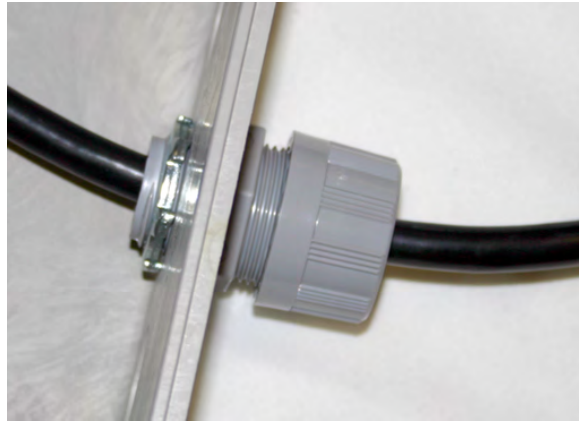

Figure 2-11 Position and secure the cable

⚠ CAUTION

If using conduit instead of the cord-grip fitting, the conduit must be sealed to prevent harmful gases and moisture from entering the Signature enclosure. Failure to seal the conduit may reduce equipment life.

8. Close the front panel and fasten with the two Phillips screws.

**2.4.3 Remote Ultrasonic
Cable Connection:
310 Ultrasonic Sensor**

1. Prepare the LaserFlow Ex connector receptacle by removing the cap (press down on the spring clip and pull out the cap).



Figure 2-12 Preparing the LaserFlow Ex connector receptacle

2. Remove the stainless steel cap from the 310 ultrasonic plug and push the protective caps from the LaserFlow Ex module and ultrasonic together.
3. Aligning the pins on the 310 ultrasonic plug with those in the connector receptacle, push the ultrasonic plug into the receptacle until the spring release "clicks".



*Figure 2-13 Secure caps and connect 310 ultrasonic plug to
LaserFlow Ex*

To be certain that the connectors are locked, lightly pull on the cable connector; the cable should be held in place by the spring release clip.

2.5 Sensor Installation Tools and Requirements

The Signature flowmeter or 2160 LaserFlow Module does not have to be mounted near the flow stream. The flowmeter can be installed at a convenient, protected location and the sensor cable can be routed through user-provided conduit back to the flowmeter.

Proper installation of the LaserFlow Ex is critical for accurate measurement.

2.5.1 Tools Required

See Appendix B.2 Equipment and Recommended Tools.

2.5.2 Sensor and Mounting Equipment Dimensions

Complete mounting assembly dimensions are provided in Figures 2-14 through .

Refer to the appropriate drawing(s) when planning the installation and adjusting the mounting hardware.

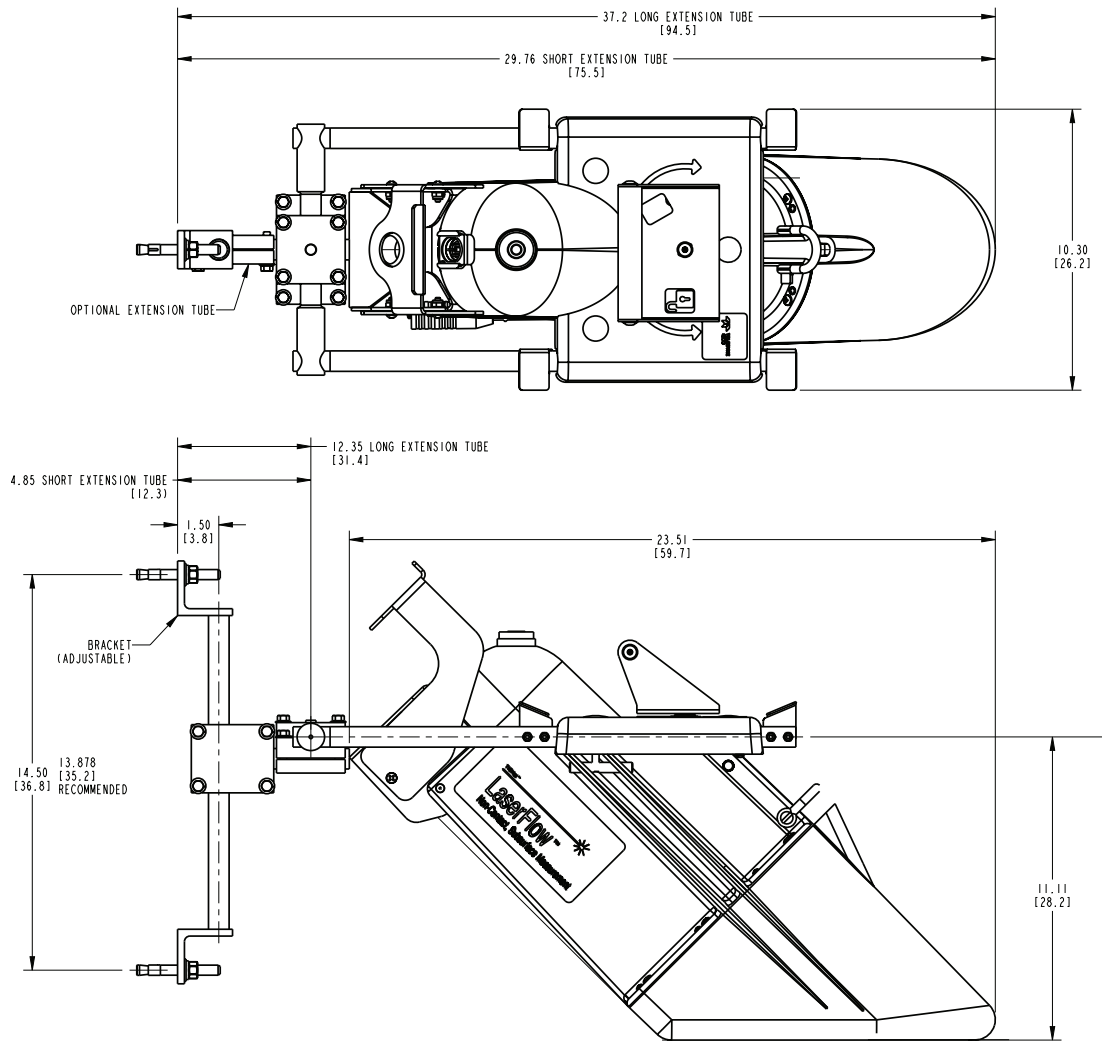

Figure 2-14 Overall dimensions including wall mounting hardware (part 1)

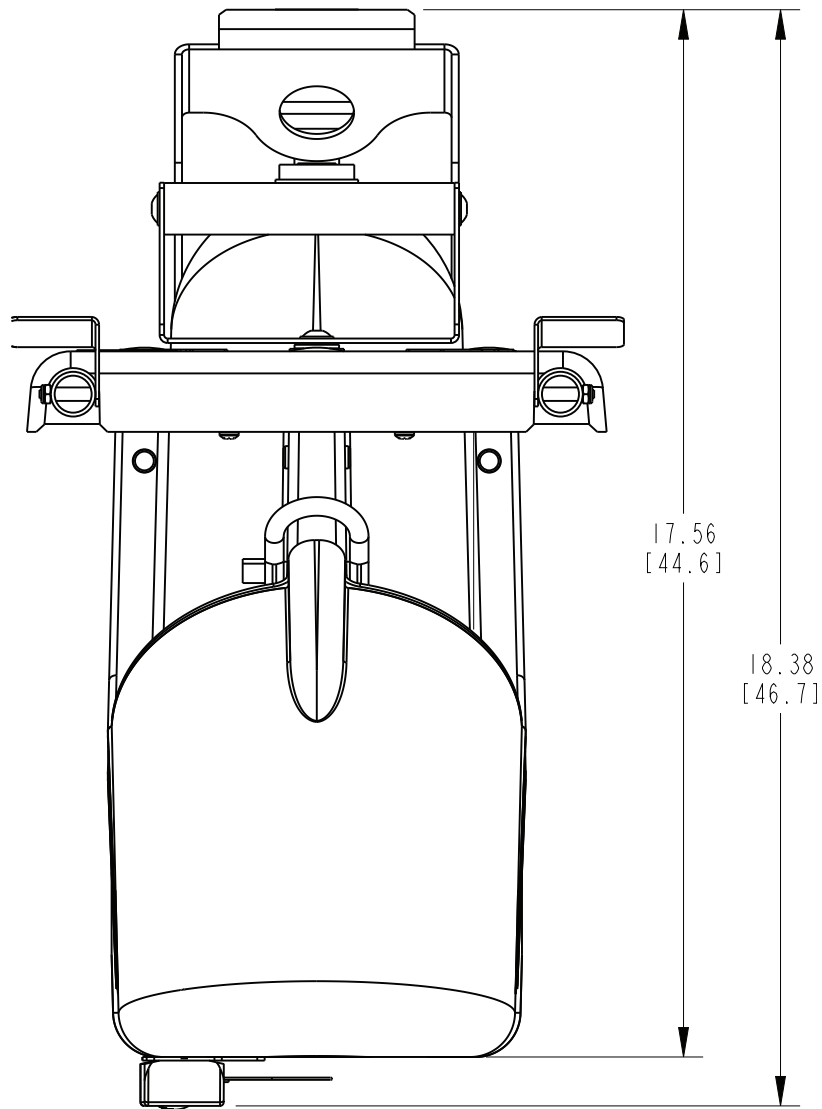
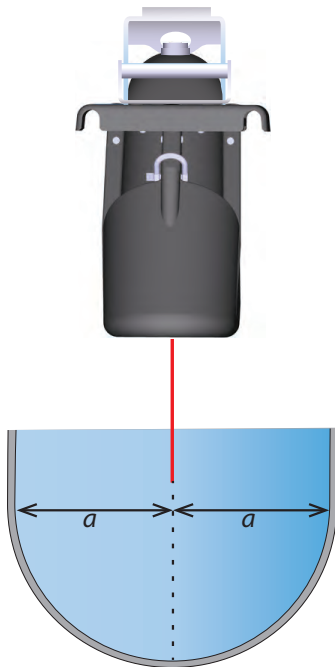
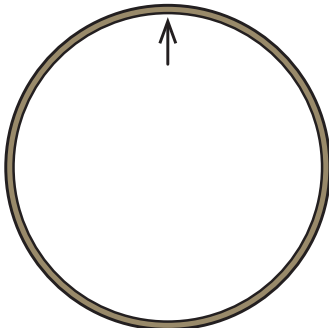

Figure 2-15 Overall dimensions including wall mounting hardware (part 2)

2.5.3 Sensor Positioning and Requirements



Center of the pipe



Top of pipe inside wall

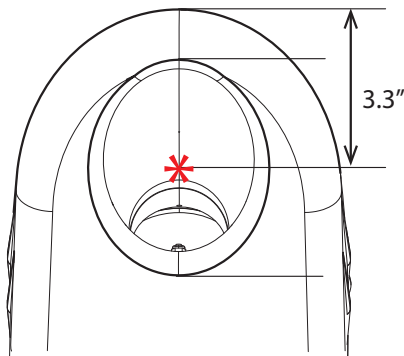

Distance from sensor tip to laser beam exit point (vertex of 45° angle)

The figure on the left shows constants that serve as reference points when planning the positioning of the sensor.

Figure 2-16, shows a typical LaserFlow Ex manhole installation.

CAUTION

For proper function, the requirements listed here must be followed exactly.

Requirements:

- Permanent Installation: Install the wall bracket perpendicular to the x-axis.
- Always center the LaserFlow Ex (and middle laser beam) relative to the pipe walls, and always use the attached circular bubble level for vertical alignment.
- Mount the LaserFlow Ex sensor with the bottom parallel with the water surface.
- Align the bottom of the LaserFlow Ex with the top of the inside wall of the inlet pipe, and as close as possible to the pipe mouth without obstructing the laser. To accomplish this, refer to the figure at left, Figure 2-16 on the next page, and the following important figures:
 - The point at which the laser exits the sensor mouth is **3.3" (8.4 cm)** from the front tip of the sensor, or the center of the opening.
 - The distance from the bottom of the LaserFlow Ex sensor to the center of the coupling tube is **10.375" (26.35 cm)**.
 - The laser beam exits the sensor mouth at a **45° angle**. (If the sensor bottom is parallel with the water surface, the laser beam will also strike the water surface at a 45° angle.)

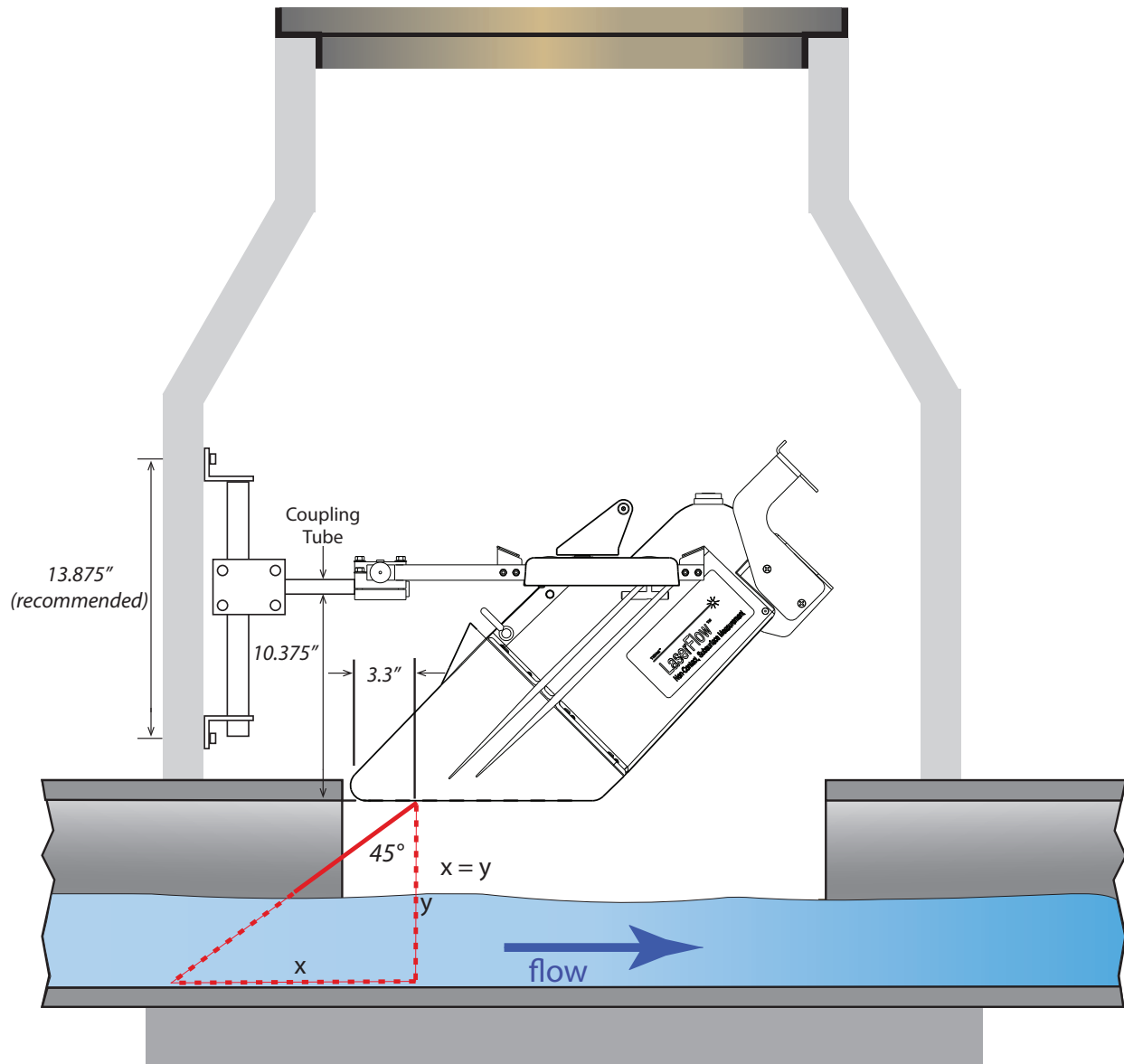

Figure 2-16 Typical manhole installation

2.6 Wall Mounting Kit

For wall mounting, identify the components listed in Figure 2-17 and Table 2-1, and perform the steps that follow. Order numbers for parts and fasteners are provided in Appendix A.

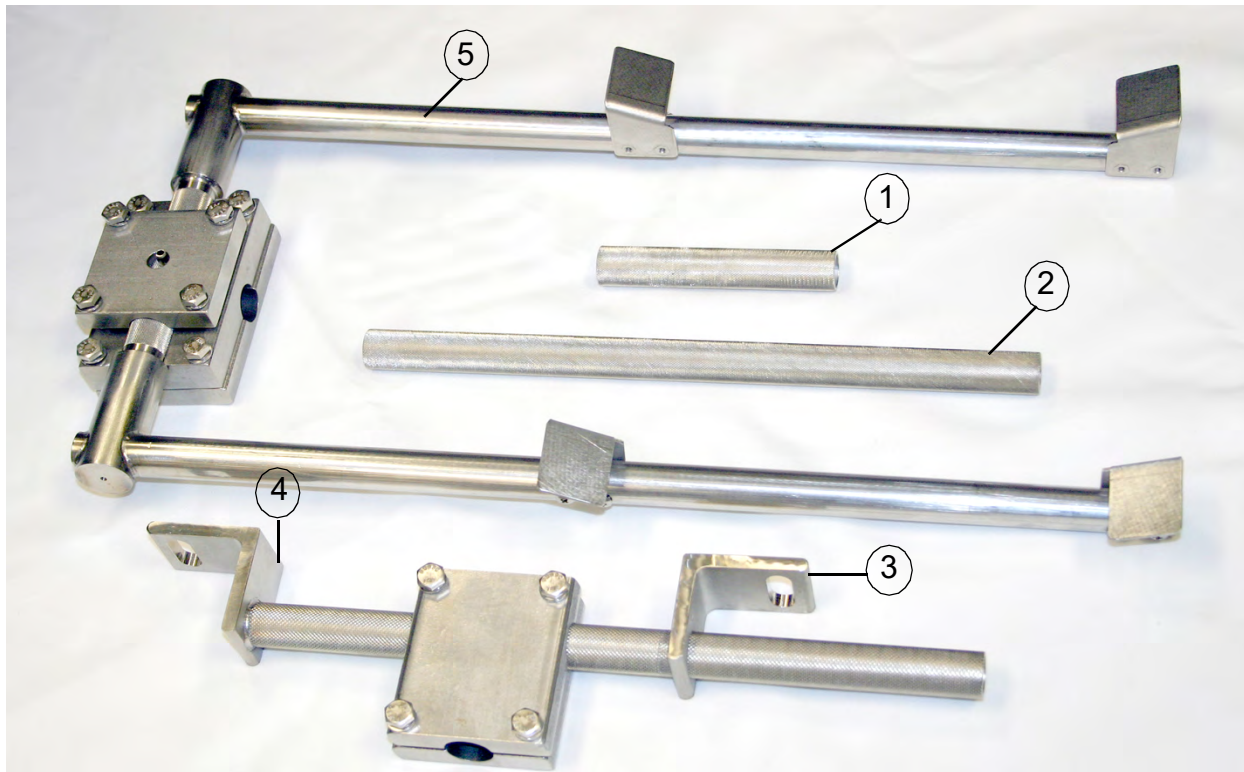

Figure 2-17 Wall mounting kit (Numbers correspond with Table 2-1)

Table 2-1 Wall Mounting Kit	
Item (Callout #)	Description
1	Tube Coupler (short)
2	Tube Coupler (long)
3	Bottom Wall Mount Angle Bracket (adjustable)
4	Mounting Shaft
5	Sensor Carrier
	SST Anchor Stud Assembly & Spring Lock Washers (for fastening brackets to wall)

2.6.1 Wall Mount Installation

Refer to the dimensions and requirements in Figure 2-18 while performing the following steps.

✓ Note

Stud anchors for concrete are provided in the mounting kit. It is recommended to drill a hole 2" (5.08 cm) deep, leaving 1" (2.54 cm) of the stud exposed.

1. Bolt or anchor the bottom angle bracket to the wall.
2. Slide the mounting shaft into the bottom angle bracket and bolt or anchor the mounting shaft to the wall.
3. Insert either the long or short tube coupler into the hole formed by the vertical clamp. Adjust the clamps to the desired height and cross-tighten the four bolts evenly until the clamp and tube coupler are firmly attached.

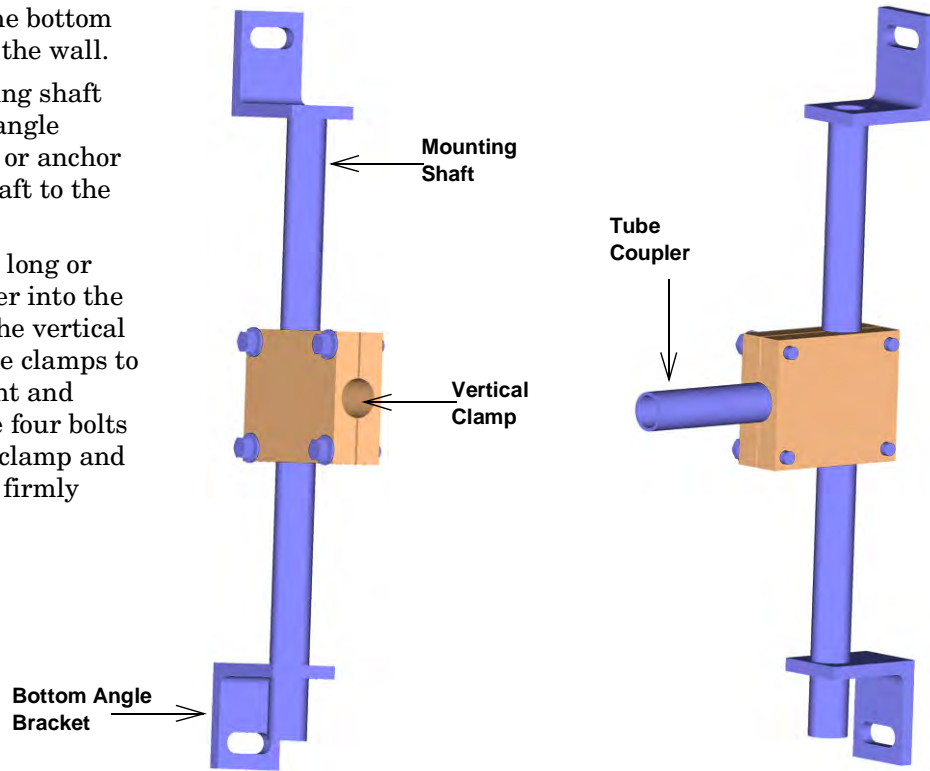

Figure 2-18 Wall Mount: Vertical clamp and vertical clamp with tube coupler inserted

4. Push the sensor carrier clamp onto the tube coupler until the coupler appears on the other side of the clamp. Align the carrier with both arms parallel to the flow surface and cross-tighten the bolts so the carrier is held firmly in position. Ensure the alignment tabs are facing up (see Figure 2-19).

Note that some realignment will be necessary following installation of the LaserFlow Ex sensor; ensure that all hardware is tightened following final alignment.

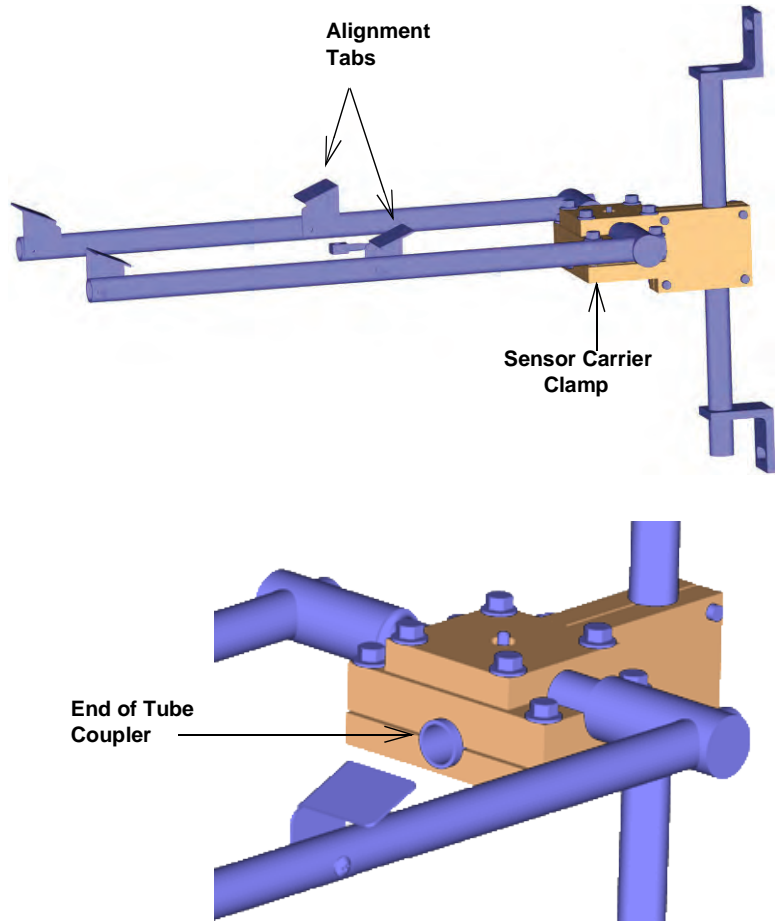

Figure 2-19 Wall Mount: Sensor carrier installed on tube coupler

Note

After initial installation and sensor alignment, the remaining steps are often possible to perform from above ground, with the optional sensor retrieval arm.

 **WARNING**

If lowering the LaserFlow Ex from above ground, ensure that it does not become dislodged while being lowered, possibly endangering any personnel who may still be below ground.

5. Lower the LaserFlow Ex sensor onto the mounting bracket between the front and rear alignment tabs, with the two mounting block grooves resting on the two carrier arms. The sensor can be installed on the carrier facing inward or outward, depending on installation requirements.

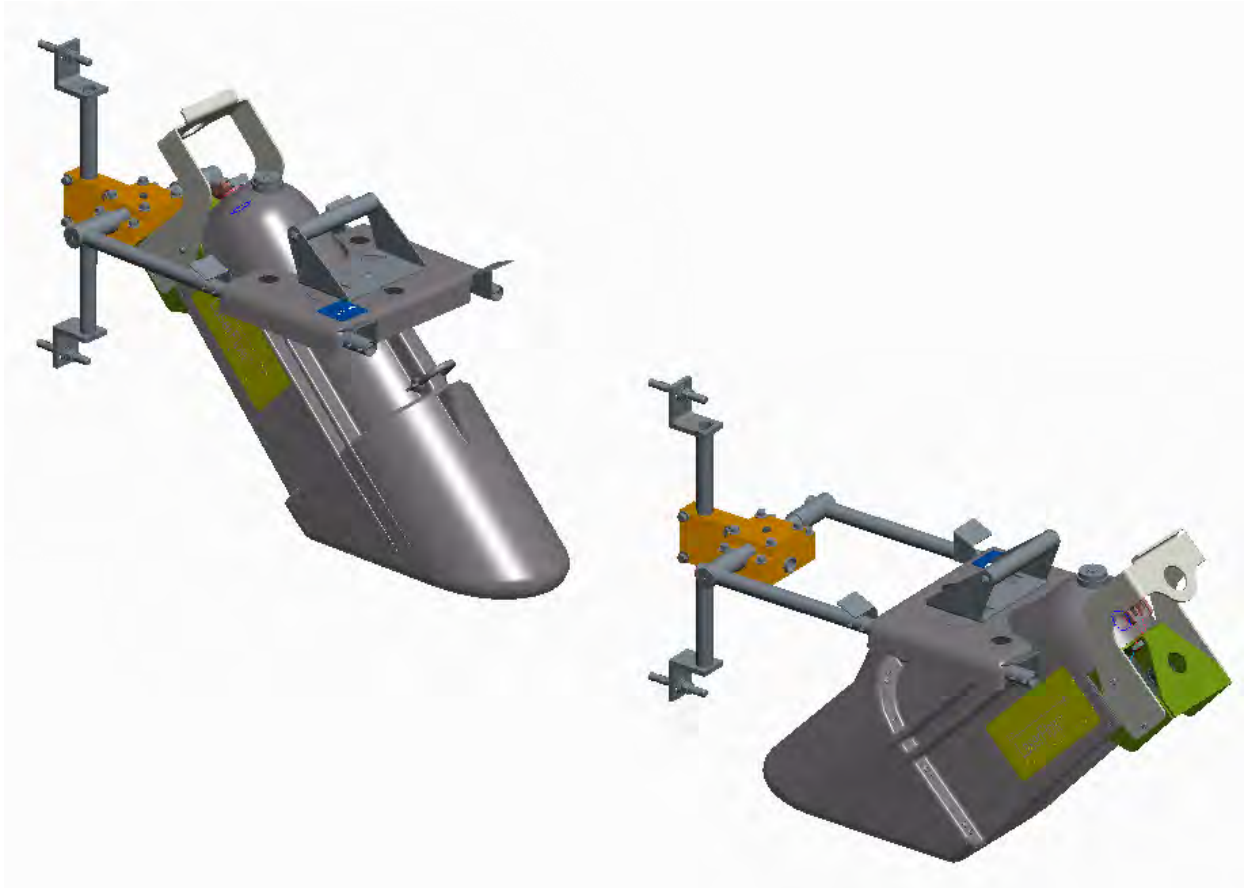

Figure 2-20 Wall Mount: Place the sensor on the carrier

6. Turn the locking handle clockwise until it locks the sensor in place.
7. Using the bubble level on top of the sensor as a guide, adjust the carrier by loosening the appropriate bolts in the sensor carrier clamp so that the bubble in the level falls within the concentric rings.
8. Turn the laser on to make final adjustments so that the laser beam hits the flow stream at the exact center of the pipe (refer to Section 3.4 for Signature or Section 4.3 for 2160).

Note

Additional assistance in adjusting the sensor's position may be obtained by activating and observing the 360 X-Axis (roll) and 360 Y-Axis (pitch) parameters.

9. Following final adjustments, ensure that all mounting bracket fasteners are tightened.

2.7 Optional Sunshade

The sunshade is an optional accessory for use when the LaserFlow Ex sensor is installed in an outdoor location in direct sunlight. The purpose of the sunshade is to prevent sunlight from striking the case of the sensor directly and heating it to a higher temperature than that of the surrounding air.

This heating, caused by the absorption of sunlight, should be avoided, as it introduces an error factor into the flowmeter's level calculations.

1. Loosen the four tee knobs (two on each side of the sunshade) and slide the two adjustable mounting blocks to the rear of the slots on each side of the sunshade.
2. Position the sunshade on top of the LaserFlow Ex sensor mount and slide the sunshade toward the rear until the four stationary mounting blocks (two on each side of the sunshade) fit under the two front alignment tabs of the LaserFlow Ex sensor carrier. See Figure 2-21.

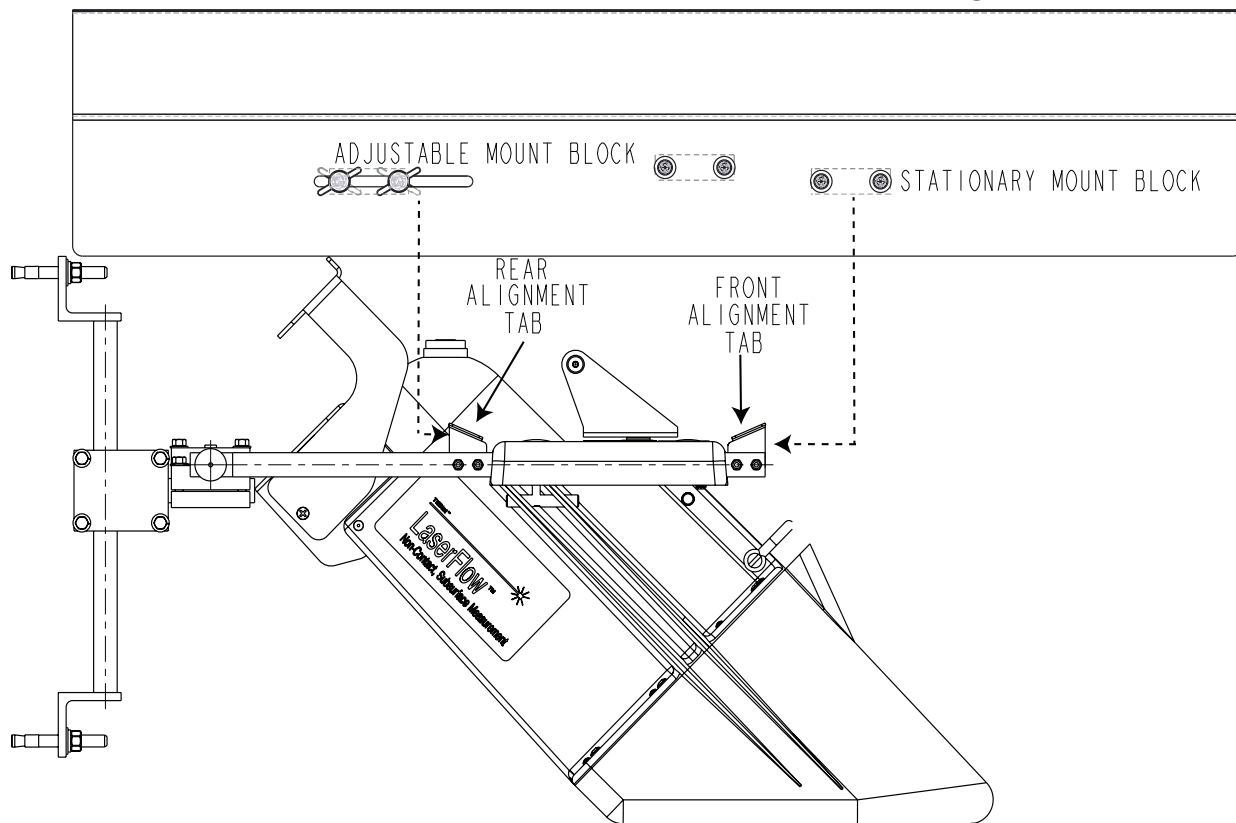

Figure 2-21 Mounting the sunshade

3. Slide the two adjustable mounting blocks (connected to the tee knobs) until they fit under the rear alignment tabs of the LaserFlow Ex sensor carrier. See Figure 2-21.

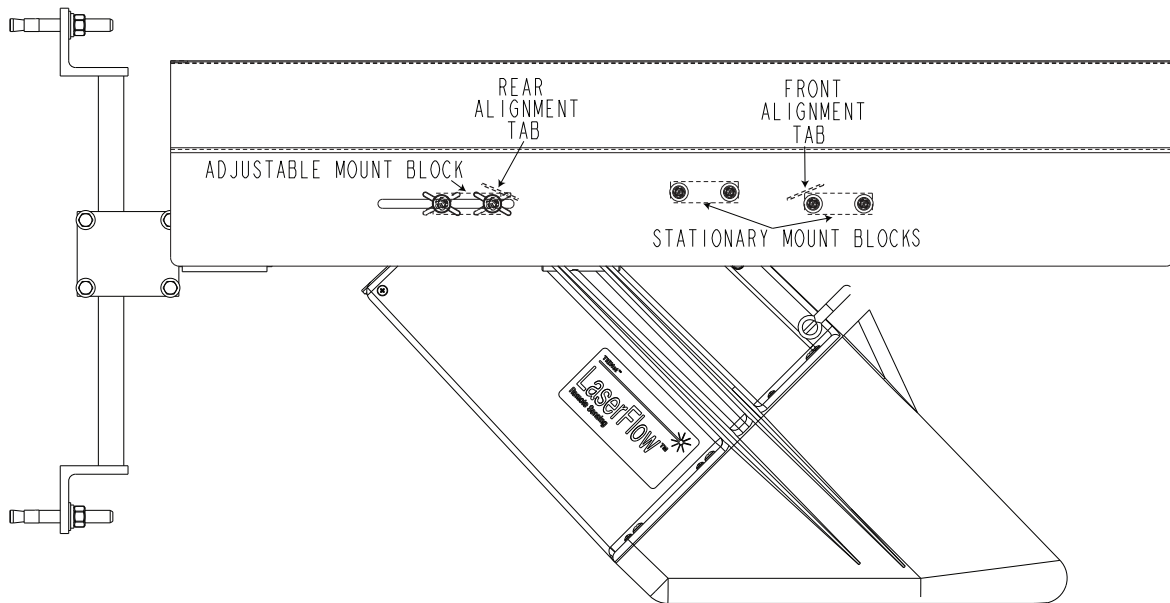

Figure 2-22 Mounted sunshade

4. Tighten the four tee knobs.

2.8 Remote TIENet Model 310 Ultrasonic Level Sensor

Refer to the TIENet 310 Ultrasonic Level Sensor Installation and Operation Guide for details.

TIENet® 360 LaserFlow Ex® Velocity Sensor

Section 3 Setup with Signature® Flowmeter

The LaserFlow Ex velocity sensor is compatible with both the Teledyne ISCO Signature flowmeter and the Teledyne ISCO 2160 LaserFlow Module. For 2160 setup instructions, refer to Section 4. For complete information about the Signature flowmeter, refer to the Signature flowmeter user manual.

3.1 Configuring the System

To configure the Signature flowmeter for operation with the

LaserFlow Ex sensor, press the “**Menu**” button () to access the top menu, and then select “**Hardware Setup**”. For all TIENet devices including the LaserFlow Ex sensor, select “**Smart Sensor Setup (TIENet)**”.

3.1.1 Updating the Device List

When the LaserFlow Ex sensor has been physically added to the system, select “**Perform Scan**” so that the flowmeter detects it. When the scan is complete, the LaserFlow Ex sensor (model number 360) appears in the list of connected devices, ready to be configured with the steps shown in Figure 3-2.

Note

From the Hardware Setup menu, “Configure Measurements” refers to defining and selecting the parameters for each connected device.

The LaserFlow Ex sensor parameters are:

360 Distance – Distance between the bottom of the sensor and the surface of the flow stream (refer to Section 3.2.2).

360 Level – Level of the flow stream surface

360 Velocity – Average velocity of the flow stream

360 Case Temperature – Internal temperature of the LaserFlow Ex sensor housing

360 Laser Temperature – Temperature of the laser assembly

360 X-Axis – Tilt about the ‘x’ axis (roll)

360 Y-Axis – Tilt about the ‘y’ axis (pitch)

360 Laser Diode Current – Current draw of the laser diode

360 Ultrasonic Signal – Strength of the ultrasonic return echo



360 Temperature – Temperature of the window

360 Sense Voltage – Measurement of window clarity (under 100 mV) –

360 Air Temperature – Temperature of surrounding (ambient) air

360 Input Voltage – TIENet voltage measured by the LaserFlow sensor

360 Doppler Power – Strength of the laser Doppler signal for velocity

The name of any parameter can be customized by highlighting it and pressing the “Enter” button () to display the character grid. Navigate the grid using the arrow keys. Select characters by pressing the “Enter” button and clear characters by pressing the “Delete” button ()

360 Distance														
Done				Cancel										
A	B	C	D	E	F	G	H	I	J	K	L	M	N	▲
O	P	Q	R	S	T	U	V	W	X	Y	Z	a	b	
c	d	e	f	g	h	i	j	k	l	m	n	o	p	
q	r	s	t	u	v	w	x	y	z		/	:	!	
@	#	\$	%	^	&	*	()	-	_	+	=	<	
>	?	,	.											▼

Figure 3-1 Character grid

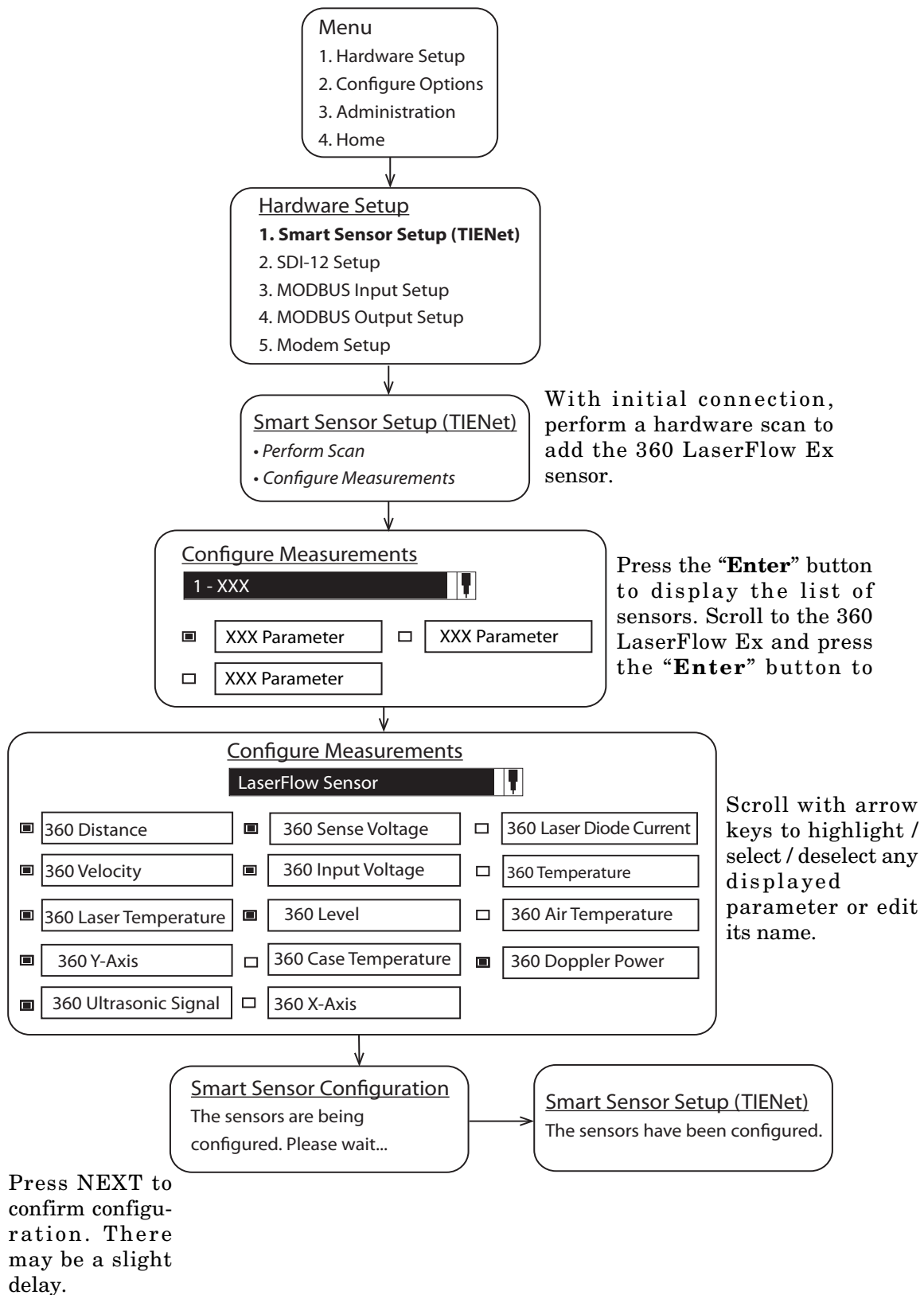

Figure 3-2 Menu Tree: LaserFlow Ex Configuration

3.2 Measurement Setup

From Measurement Setup (Figure 3-3), select Level Input Setup to define the blanking distances and Velocity Input Setup to set velocity direction and access advanced settings.

✓ Note

Refer to the Signature user manual for information about Flow Rate Input Setup and Volume Input Setup.

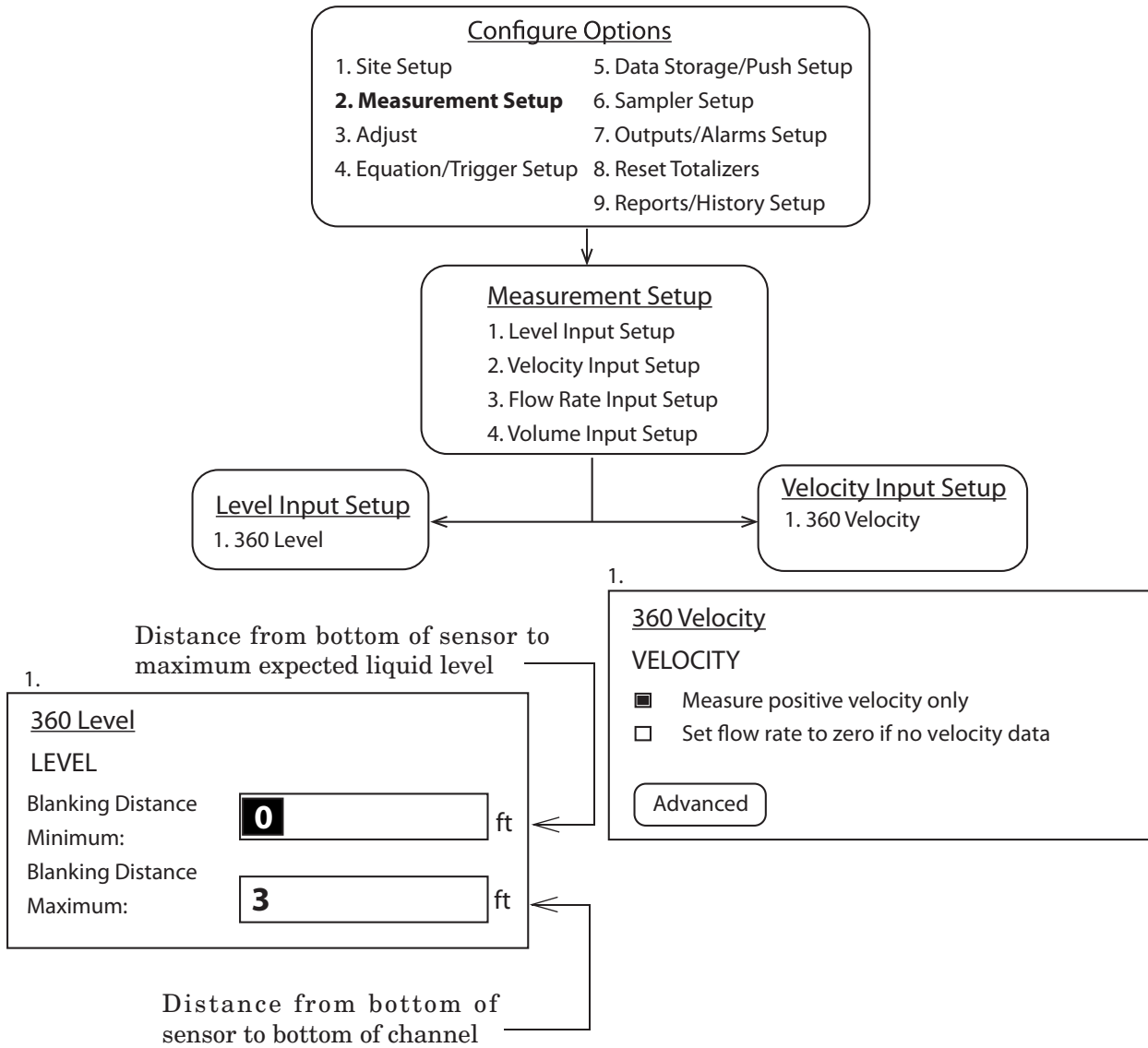

Figure 3-3 Measurement Setup: Sensor input settings

3.2.1 360 Level

The **Minimum Blanking Distance** is the distance from the bottom of the sensor to the liquid surface at the highest expected level. Depending on the elevation of your sensor, this value may be increased to help ensure that echoes read by the flowmeter come only from the surface of the flow stream, and not off the walls or sides of the channel.

The **Maximum Blanking Distance** is the distance between the bottom of the sensor and the bottom of the channel (i.e., zero level). A larger value than calculated can be entered.

If using the LaserFlow Ex module with the 310 remote ultrasonic sensor and horizontal sensor mounting bracket, the maximum blanking distance is the distance between the bottom of the mounting bracket and the bottom of the channel.

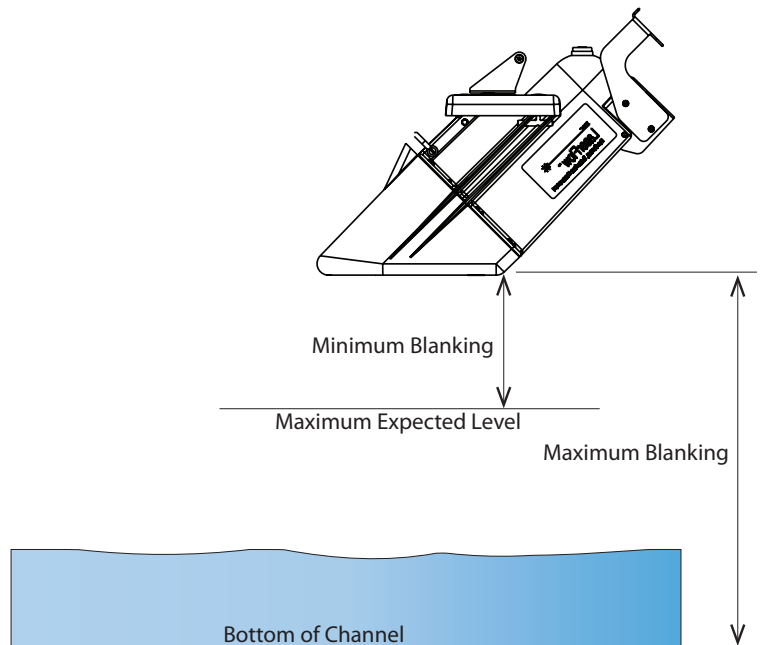

Figure 3-4 Blanking distance for LaserFlow Ex with built-in sensor or with remote ultrasonic sensor

3.2.2 360 Velocity

When the **Measure Positive Velocity only** option is selected, the LaserFlow Ex will not attempt to determine flow direction.

3.2.3 LaserFlow Ex Velocity Advanced Settings

The LaserFlow Ex **Advanced Settings** are pre-programmed into the sensor. However, if your application requires any custom configuration, the Advanced button opens the Advanced settings window (refer to Figure 3-5).

Input Velocity Coefficients – The relationship of the three Input Velocity Coefficients A, B and C can be expressed as:

$$\bar{V} = A (\text{offset}) + B * (\text{Measured Velocity}) + C * (\text{Measured Velocity})^2$$

Coefficient A is an additive offset value to correct the Measured Velocity for any additive bias. The value for A must be expressed in units of meters/second. The default is “0”.

Coefficient B is a multiplicative scalar for correcting the Measured Velocity for any linear multiplicative bias. The value for B is unitless. The default is “0.9”.

Coefficient C is another scalar to correct the Measured Velocity for any nonlinear bias. The value for C must be expressed in units of seconds/meter, so that the resulting value for the Reported Velocity Reading will be in units of meters/second. The default is “0”.

Spectral Averages – The value for Spectral Averages may be used to reduce sampling time and increase Doppler power under certain flow conditions. The default is “5000”. If the flow is consistently turbulent or erratic and causing low Doppler power or velocity dropouts, enter a lower value, such as 3000. This will decrease sampling time and reduce noise in the Doppler signal caused by fluctuating velocity in the flow stream.

Re-home Count – For testing purposes only. For more information, contact Products Support Specialist Group (PPSG).

Adaptive Focus – Adaptive Focus enables the LaserFlow Ex module to scan above and below the standard focus point, then adjust the focus to the point with the best signal strength. To enable Adaptive Focus functionality, select the “**Adaptive Focus**” box.

Positive Downstream – Select the “**Positive Downstream**” box when the LaserFlow Ex sensor is pointed downstream. This selection reverses the sign on velocity readings such that positive velocity values indicate the direction of flow is in the same direction as the laser beam.

Maximum Distance – LaserFlow Ex (X0 hardware version) does not support directional velocity measurements.

Maximum Velocity – LaserFlow Ex (X0 hardware version) does not support directional velocity measurements.

Steep Slope LaserFlow Ex Focusing – If the pipe is on a slope greater than 1%, select the “**Enable Slope Setting**” box. By default, this option is disabled.

Parallel to Channel Slope – If the sensor is parallel to the channel slope, select “**Parallel to Channel Slope**”. Measure from the front of the sensor carrier to the bottom of the channel. Then measure from the back of the sensor carrier to the bottom of the channel. Ensure the distance is equal. Adjust the sensor carrier as necessary. By default, this option is enabled when the “Enable Slope Setting” box is selected. See Figure 4-11 in Section 4.

Slope Percentage – If the slope of the pipe is known, mount the sensor level with the Earth, using the bubble level mounted on the top of the sensor and then enter the Slope Percentage in the field. By default, this option is disabled when the “Enable Slope Setting” box is selected. A positive slope value is used when the laser beam is pointed upstream. See Figure 4-12 in Section 4.

Optical Clarity – Sense voltage detects fog on the window of the LaserFlow Ex sensor. When the sense voltage is greater than 150 mV, the defogger is activated. The defogger is enabled from 1 to 5 minutes, depending on the severity of the fog.

Note

In locations with severe fogging potential, Teledyne ISCO recommends increasing battery capacity or monitoring the site more frequently.

To enable Optical Clarity, select “**Active**”. To disable Optical Clarity, select “**Passive**”. The default is “Active”.

Remote Distance Measurement – The Remote Distance Measurement options are active only when the LaserFlow Ex module is connected to the TIENet 310 remote ultrasonic sensor.

- Be sure defaults are added for integral 310 Ex ultrasonic level sensor.

Advanced

Warning: Any changes to the following data can adversely affect the performance of this Instrument!
 Select BACK to cancel or NEXT to continue.

A + (B * v) + (C * v²)
 Input Velocity Coefficients

A (default=0): m/s

B (default=0.9):

C (default=0): s/m

Spectral Averages (default=5000):

Re-home Count (default=100):

Start Bin:

Stop Bin:

Max Focus Depth: in

Min Doppler Power: in

Focus Learning Algorithm

Peak Detect

Adaptive Focus

Remote Distance Measurement

US Distance to Bottom in

LaserFlow Distance to Bottom in

Horizontal Mount

LaserFlow Directional Velocity

Focus Downstream

Maximum Distance: ft

Maximum Velocity: ft/s

Steep Slope LaserFlow Focusing

Enable Slope Setting

Parallel to Channel Slope

Slope Percentage: %

Optical Clarity

Active

Passive

For use with the remote 310 ultrasonic level sensor.

Figure 3-5 Measurement setup: Advanced settings for LaserFlow Ex sensor

3.3 360 Velocity Grid

The 360 Velocity screen has a grid containing 15 possible measurement points. Use the Shortcuts > Adjust function to navigate to this screen (refer to Figure 3-6).

The measurement points are activated and deactivated with the arrow and Enter keys. To save the measurement settings, highlight Update and press Enter.

As the LaserFlow Ex begins to take readings, the grid becomes populated with a velocity reading and time stamp for each active measurement point (points where a valid reading could not be obtained will display the word “invalid”).

Prior to operation, the LaserFlow Ex sensor must be set up for measurement using the 360 Velocity grid. Refer to Section 3.4.

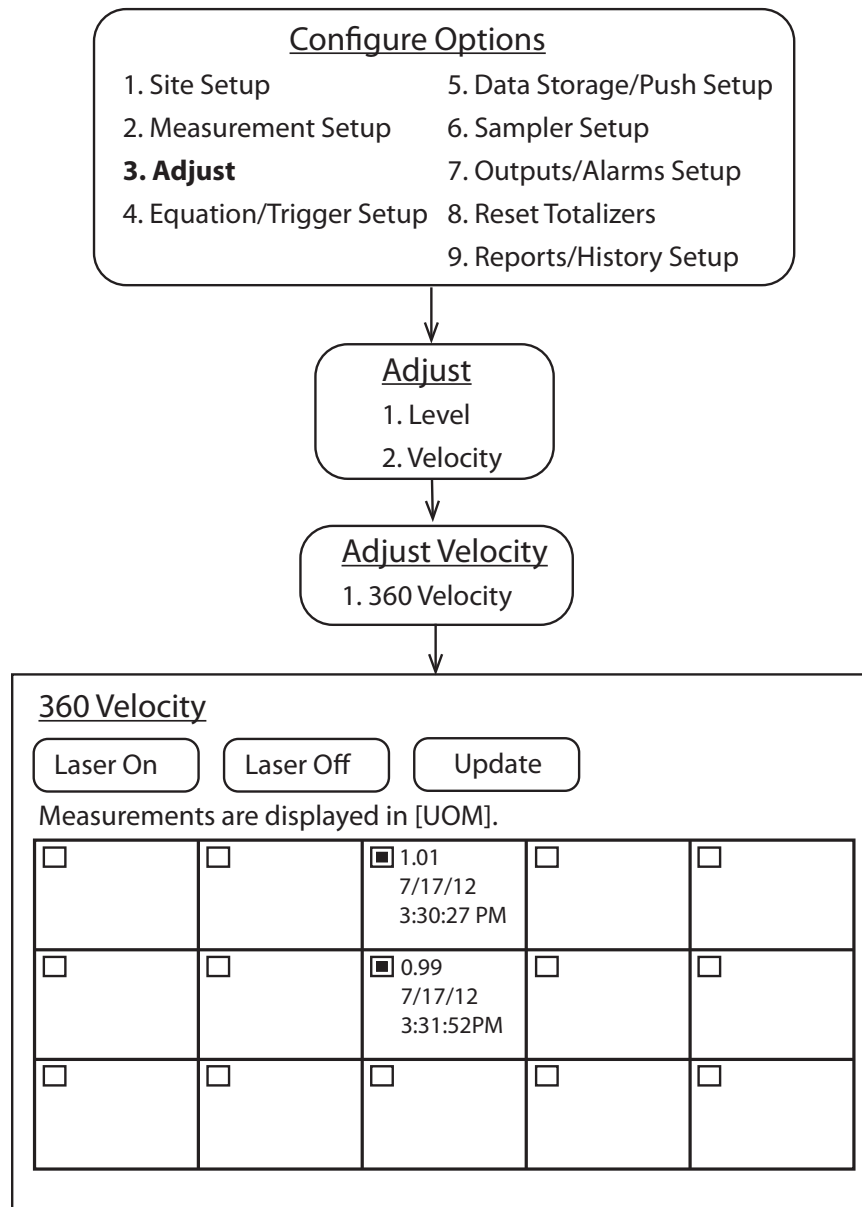
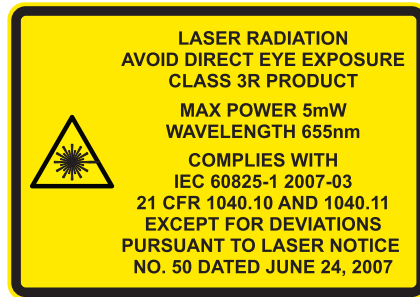

Figure 3-6 360 Velocity grid

3.4 Sensor Positioning and Adjustment



3.4.1 Centering the LaserFlow Ex Sensor

Laser On

Proper positioning of the LaserFlow Ex sensor is critical for optimal velocity measurement. In center position, the laser beam must strike the flow stream precisely in the center.

The beam automatically moves to the top center position.

Select Laser On and press Enter. This will keep the laser beam on continuously for 10 minutes or until Laser Off is selected, allowing the beam to be used for fine-tuning the sensor's position.

Note

When sensor positioning is completed, securely tighten all mounting hardware.

3.4.2 Laser Velocity Measurement Point Selection

Once the LaserFlow Ex sensor is installed over the flow stream, some installations may only require the center laser position for velocity measurement.

For installations requiring multiple measurement points, the next step is to determine which points will be used. To do so, activate all 3 points and wait for all of them to display their readings. This process may take up to 2 minutes.

Each point will display a velocity reading and time stamp, or "Invalid." Deselect "Invalid" and undesired points. The fewer points selected, the less time required to complete one velocity measurement.

Select the 3 measurement points and click UPDATE.

360 Velocity

Measurements are displayed in [UOM].

<input type="checkbox"/>	<input type="checkbox"/>	<input checked="" type="checkbox"/> 1.01 7/17/12 3:30:27 PM	<input type="checkbox"/>	<input type="checkbox"/>
<input type="checkbox"/>	<input type="checkbox"/>	<input checked="" type="checkbox"/> 0.99 7/17/12 3:31:52PM	<input type="checkbox"/>	<input type="checkbox"/>
<input type="checkbox"/>	<input type="checkbox"/>	<input checked="" type="checkbox"/> Invalid	<input type="checkbox"/>	<input type="checkbox"/>

360 Velocity

Measurements are displayed in [UOM].

Deselect invalid (and undesired) points and click UPDATE.

<input type="checkbox"/>	<input type="checkbox"/>	<input checked="" type="checkbox"/> 1.01 7/17/12 3:30:27 PM	<input type="checkbox"/>	<input type="checkbox"/>
<input type="checkbox"/>	<input type="checkbox"/>	<input checked="" type="checkbox"/> 0.99 7/17/12 3:31:52PM	<input type="checkbox"/>	<input type="checkbox"/>
<input type="checkbox"/>	<input type="checkbox"/>	<input type="checkbox"/>	<input type="checkbox"/>	<input type="checkbox"/>

Figure 3-7 Selection of velocity measurement points

3.4.3 Ultrasonic Level Adjustment

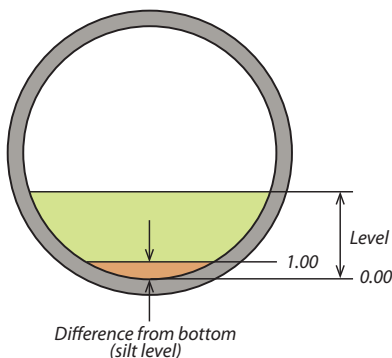

Once the LaserFlow Ex sensor is installed over the flow stream, measure the present liquid level from the bottom of the channel (if there is a difference between the bottom of the channel and zero level, save this value for reference in flow calculation) and enter this value for Level, under Adjust options. Then highlight **Adjust** and press Enter to confirm.

From this screen, you can also update the display to show the current level of the stream.

Note

Level adjustment of a newly installed and activated sensor should be performed only after the sensor is allowed to stabilize under site conditions (allow approximately one hour per 10 °F difference between storage and operating environments).

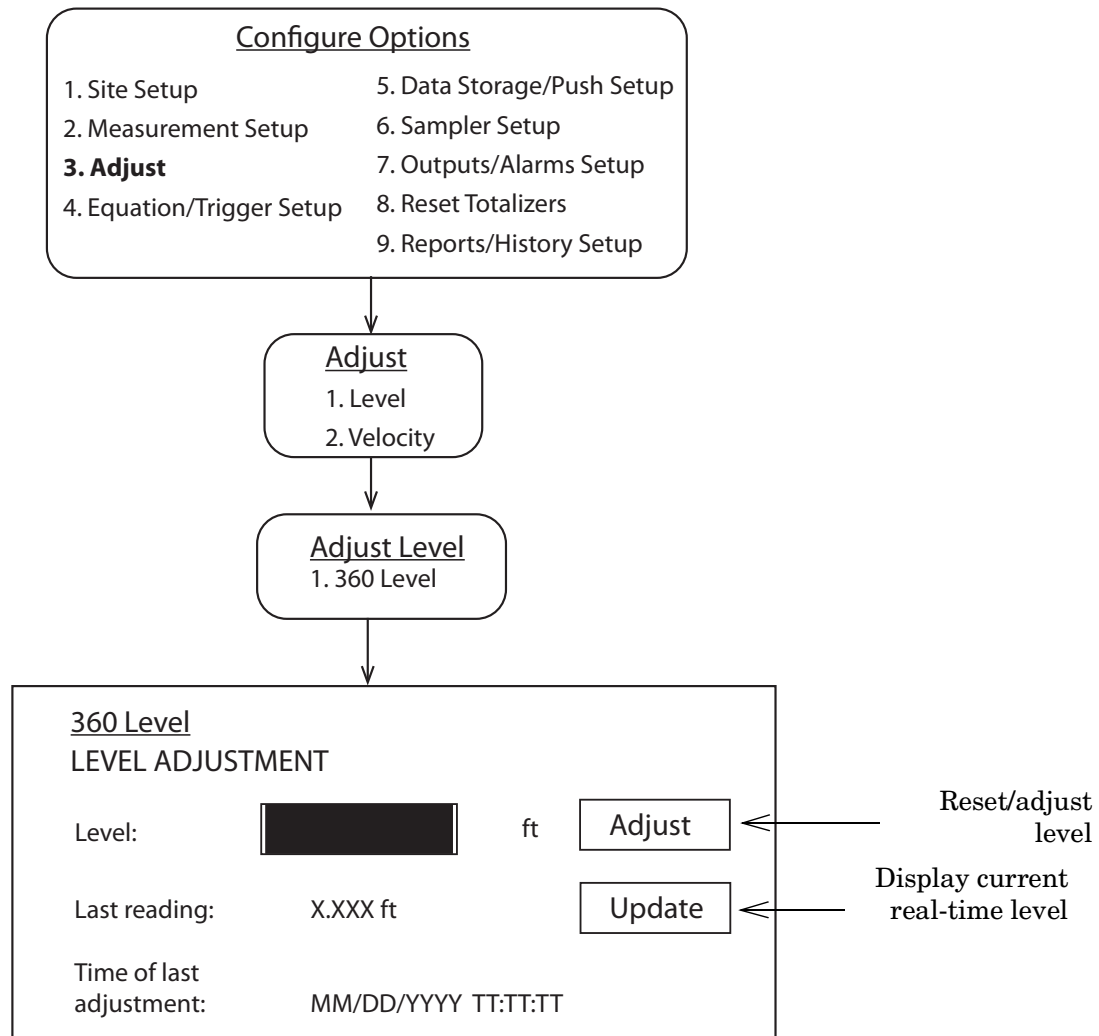

Figure 3-8 Ultrasonic level adjustment

3.5 Contact Teledyne ISCO

If you have further questions about the installation, operation, and maintenance of your TIENet device, please contact Environmental Product Support at:

Teledyne ISCO
 4700 Superior St.
 Lincoln, NE 68504
 Phone: 866 298-6174 or 402 464-0231
 Fax: 402 465-3022
 E-mail: iscowatersupport@teledyne.com

TIENet® 360 LaserFlow Ex® Velocity Sensor

Section 4 Setup with 2160 LaserFlow Module

The LaserFlow Ex sensor is compatible with both the Teledyne ISCO 2160 LaserFlow Module and the Teledyne ISCO Signature flowmeter. For Signature setup instructions, refer to Section 3.

The 2160 module is programmed and set up using Teledyne ISCO Flowlink® software. This section of the manual describes activation of connected sensors, and basic LaserFlow Ex.

This section of the manual assumes the 2160 site is already configured in Flowlink, and the 2160 module is connected to Flowlink. Detailed Flowlink instructions are available in the Flowlink Windows Help and also in the Flowlink software user manual. For complete information about the 2160 LaserFlow Module, refer to the 2160 LaserFlow Module Installation and Operation Guide.

4.1 Activating Connected Sensors

To add an available (connected) LaserFlow Ex sensor and activate in Flowlink, select the **TIENet** tab (Figure 4-1), then highlight the appropriate LaserFlow module 2160 module, and click the “**Configure**” button.

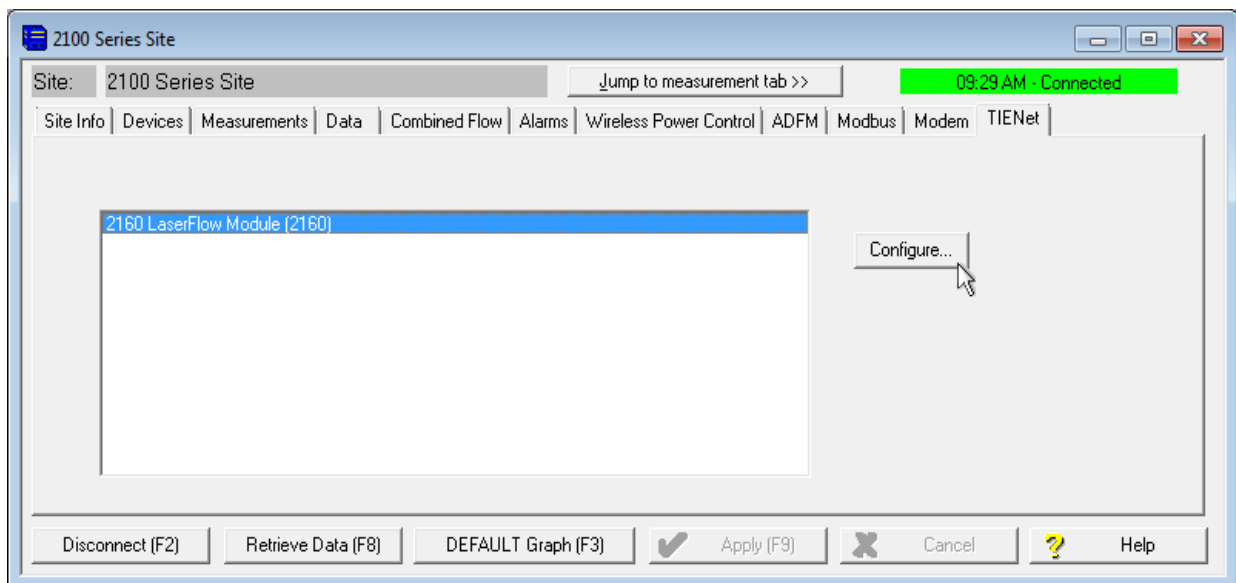

Figure 4-1 Activate connected sensors in Flowlink

A box is displayed, listing active and available TIENet Devices. Click the **“Scan”** button to detect any newly connected LaserFlow Ex or 350 Area Velocity sensors. Devices will appear in the Available TIENet Devices pane.

Highlight the appropriate device(s) and click the **“Add”** button to activate. Active TIENet devices will appear in the Active TIENet Devices pane. Click the **“OK”** button.

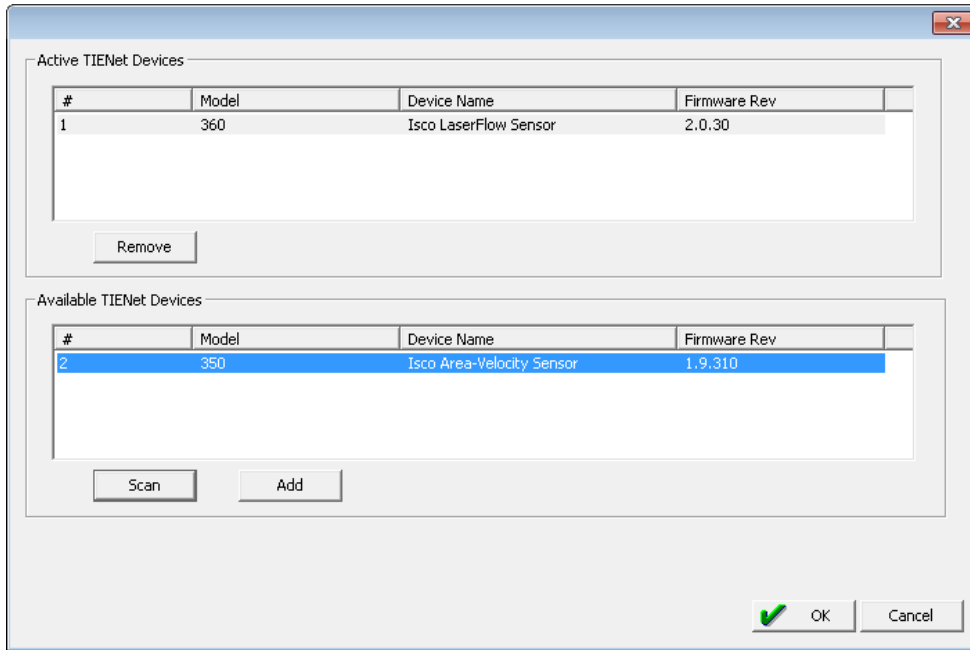

Figure 4-2 Activating connected sensors in Flowlink

4.2 Measurement Display and Settings

The **Measurements** tab in the Site window lists the data types being measured by the 2160 module and displays real-time measurements.

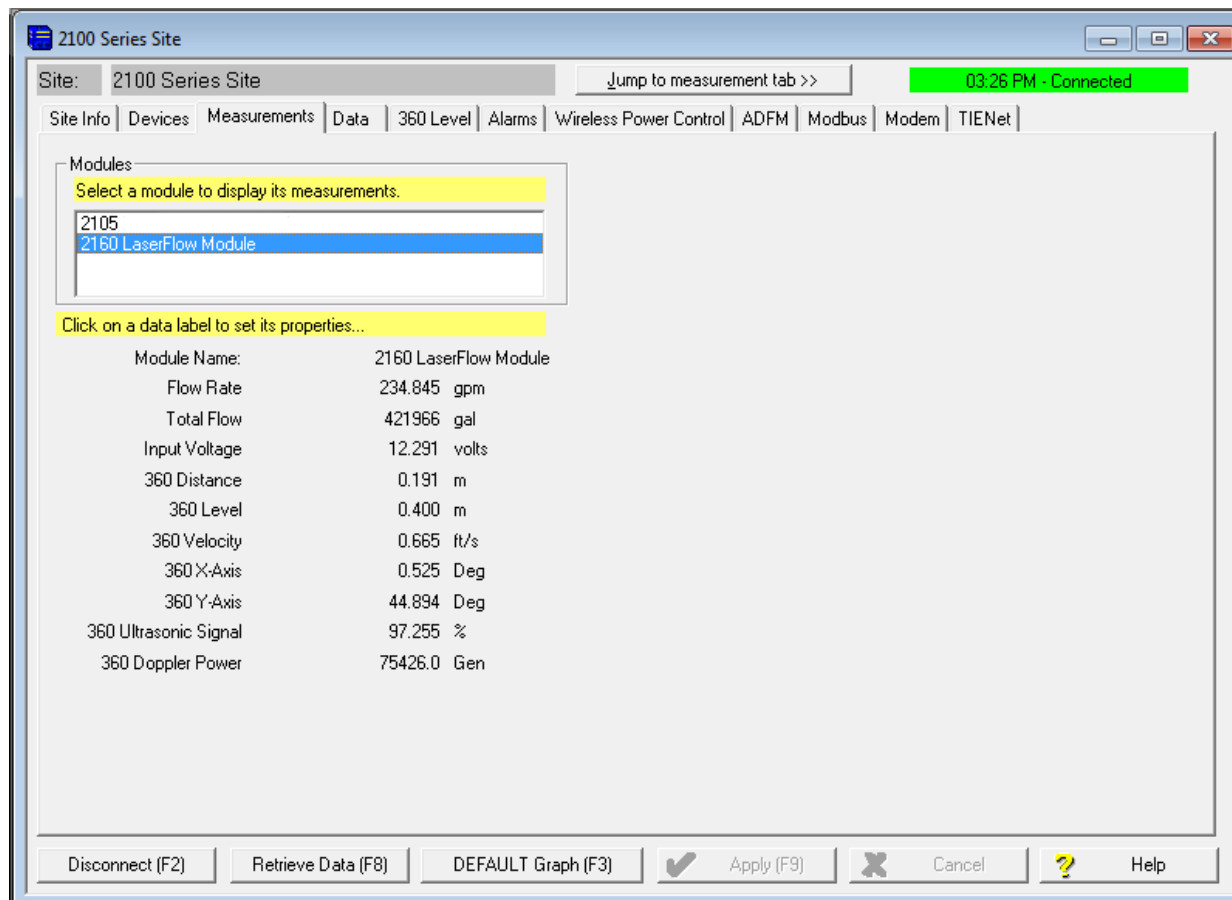

Figure 4-3 Measurements tab: Displays real-time measurements

To select and configure any parameter for your connected devices, click the “**Jump to measurement tab**” button at the top of the Site window and hover over the 2160 LaserFlow Module. Explanations for the listed measurements are provided in Figure 4-4.

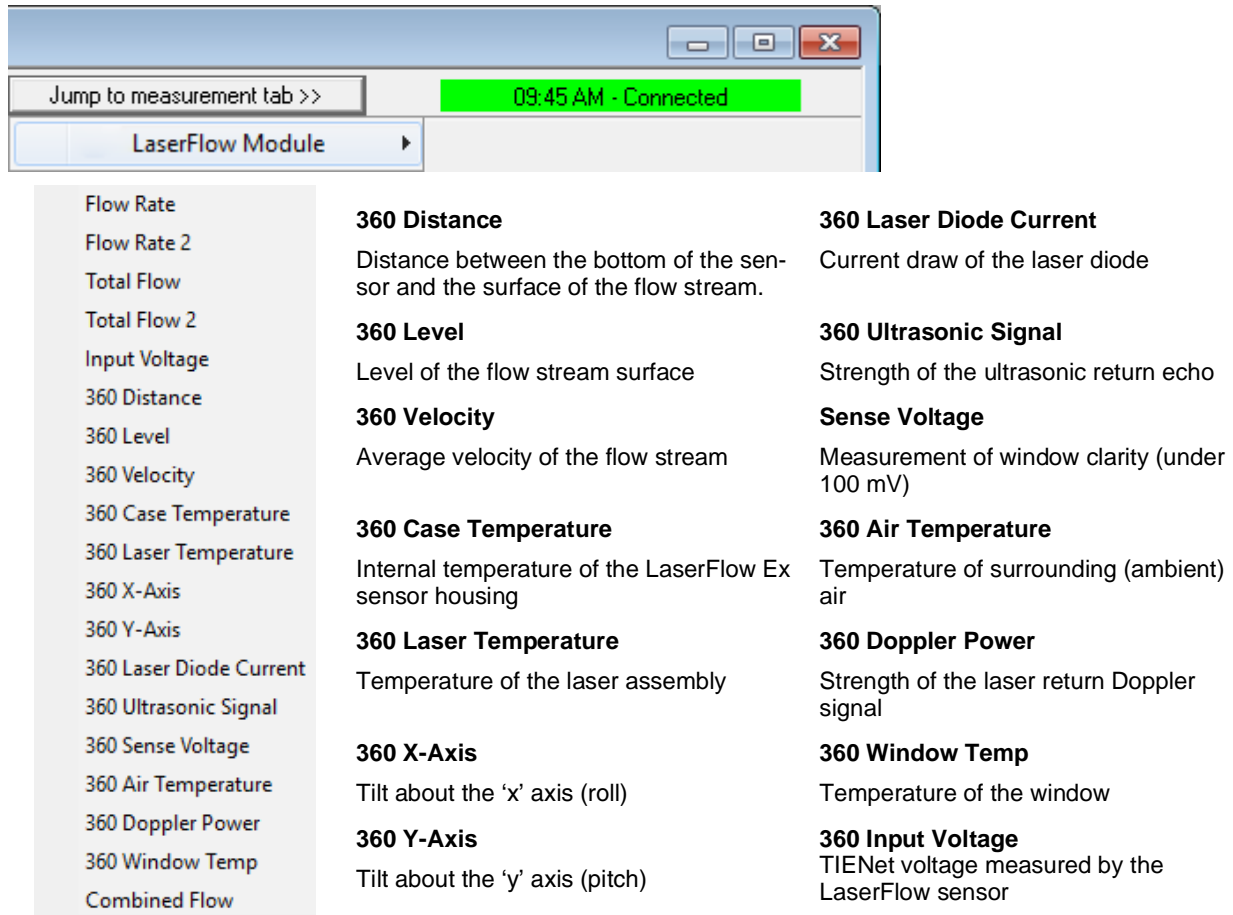

Figure 4-4 Drop down list of measurements for 2160 Module

Click on any parameter on the Measurements tab or in the Jump to Measurements tab list to open a dedicated tab to view details or set up data storage.

To prevent a parameter from being displayed on the Measurements tab, select the **Hide in Measurements** box.

The settings for level and velocity input are defined on their respective tabs in Flowlink. To save any changes made to the settings, click the “**Apply**” button.

4.2.1 360 Level

Ultrasonic Level Adjustment

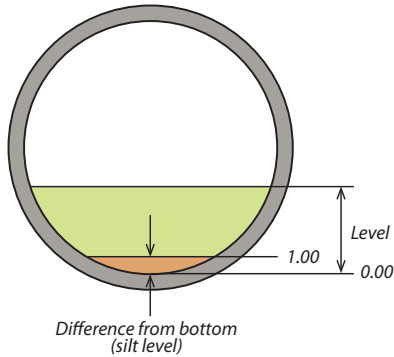

The **Measurement** field displays the most recent level reading. Once the LaserFlow Ex sensor is installed over the flow stream, measure the present liquid level from the bottom of the channel (if there is a difference between the bottom of the channel and zero level, save this value for reference in flow calculation). Enter this value in the Adjust level field. After the “**Apply**” button is clicked, the level you entered will appear in the Measurement field.

Note

Level adjustment of a newly installed and activated sensor should be performed only after the sensor is allowed to stabilize under site conditions (allow approximately one hour per 10 °F difference between storage and operating environments).

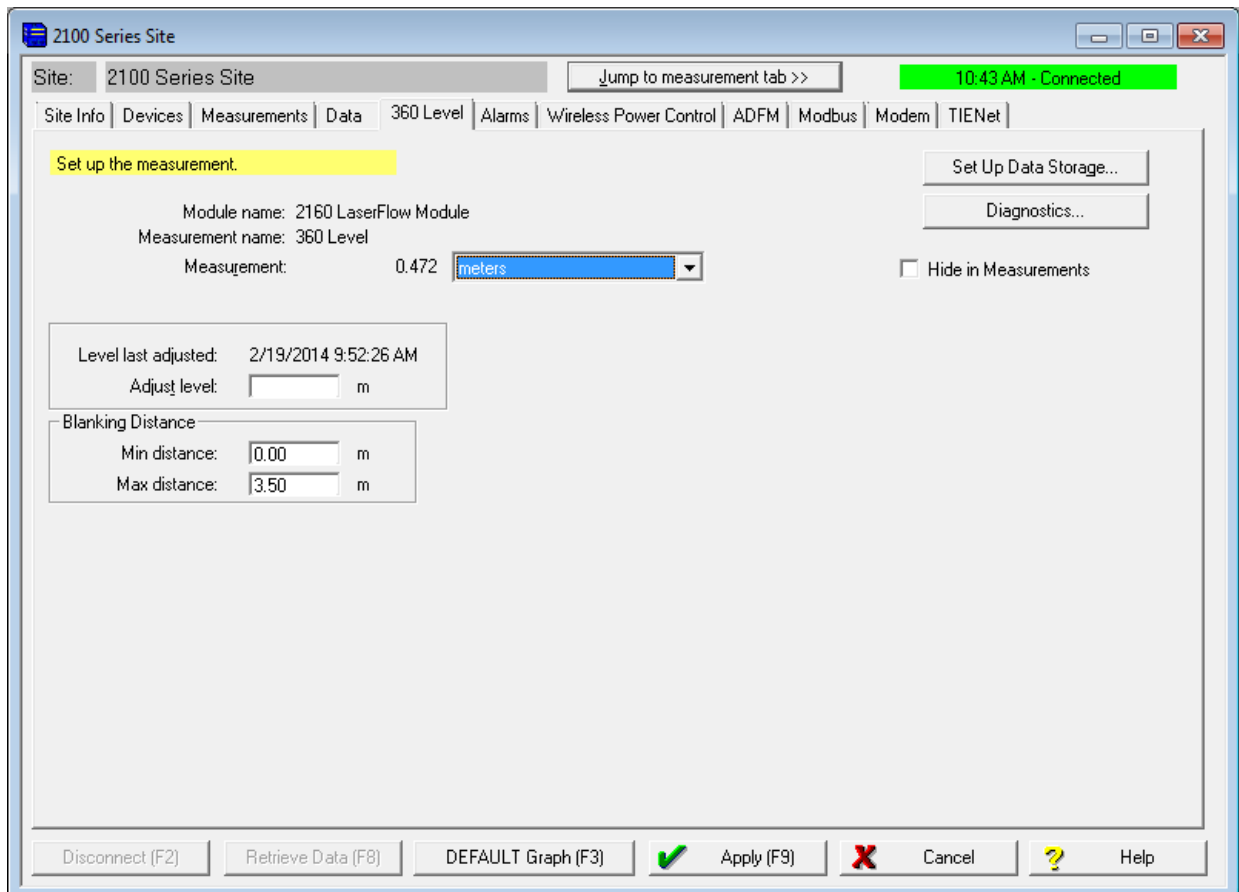

Figure 4-5 360 Level Measurement tab in Flowlink

The **Minimum Blanking Distance** is the distance from the bottom of the sensor to the liquid surface at the highest expected level. Depending on the elevation of the sensor, this value may be increased to help ensure that echoes read by the flowmeter come only from the surface of the flow stream, and not off the walls or sides of the channel.

The **Maximum Blanking Distance** is the distance between the bottom of the sensor and the bottom of the channel (i.e., zero level). A larger value than calculated can be entered.

If using the LaserFlow Ex module with the 310 remote ultrasonic sensor and horizontal sensor mounting bracket, the maximum blanking distance is the distance between the bottom of the mounting bracket and the bottom of the channel.

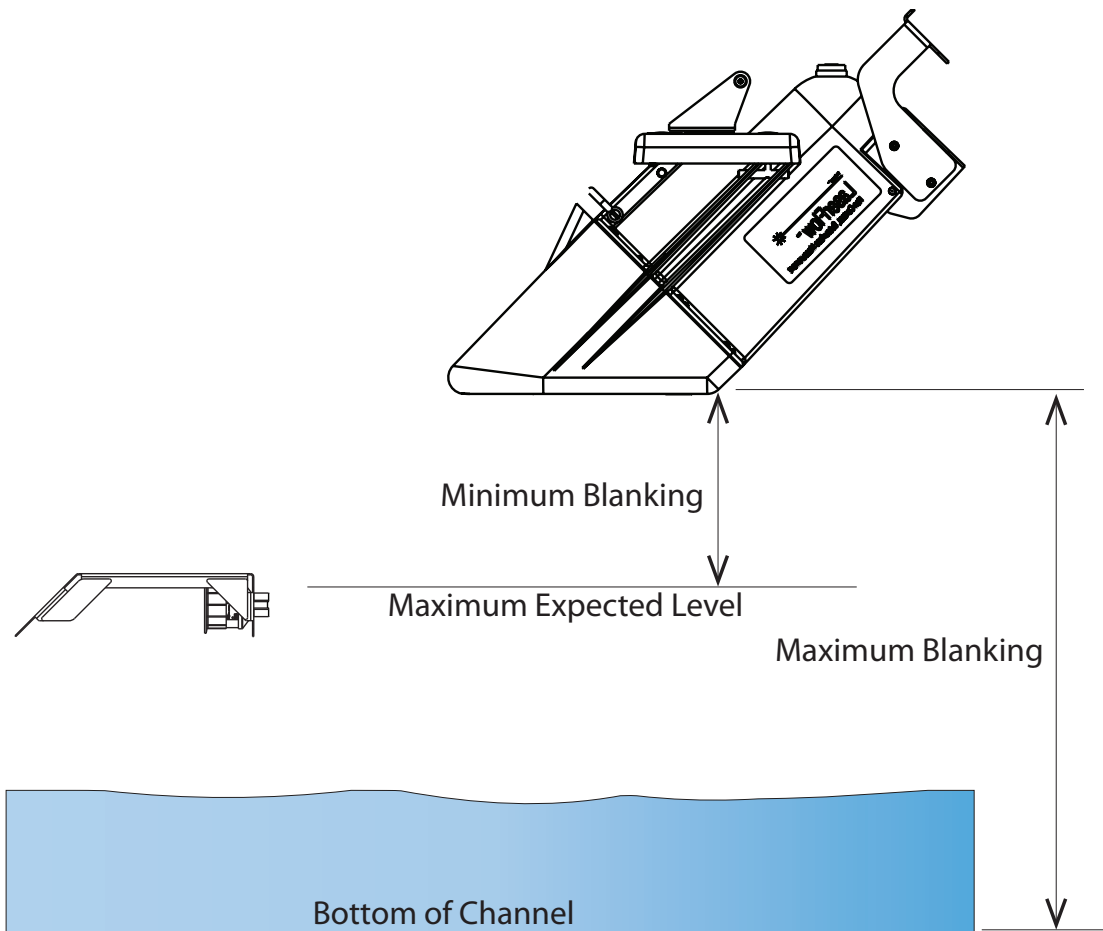

Figure 4-6 Blanking distance for LaserFlow Ex with built-in sensor or 310 remote ultrasonic sensor

4.2.2 360 Velocity

The 360 Velocity measurement tab has a grid containing 3 possible measurement points. The measurement points are activated and deactivated by selecting or deselecting the appropriate check box. To save the measurement settings, click the “**Apply**” button (F9).

As the LaserFlow Ex begins to take readings, the grid becomes populated with a velocity reading and time stamp for each active measurement point (points where a valid reading could not be obtained will display the word “invalid”).

Prior to operation, the LaserFlow Ex sensor must be set up for measurement using the 360 Velocity grid. Refer to Section 4.3 *Sensor Positioning and Adjustment*

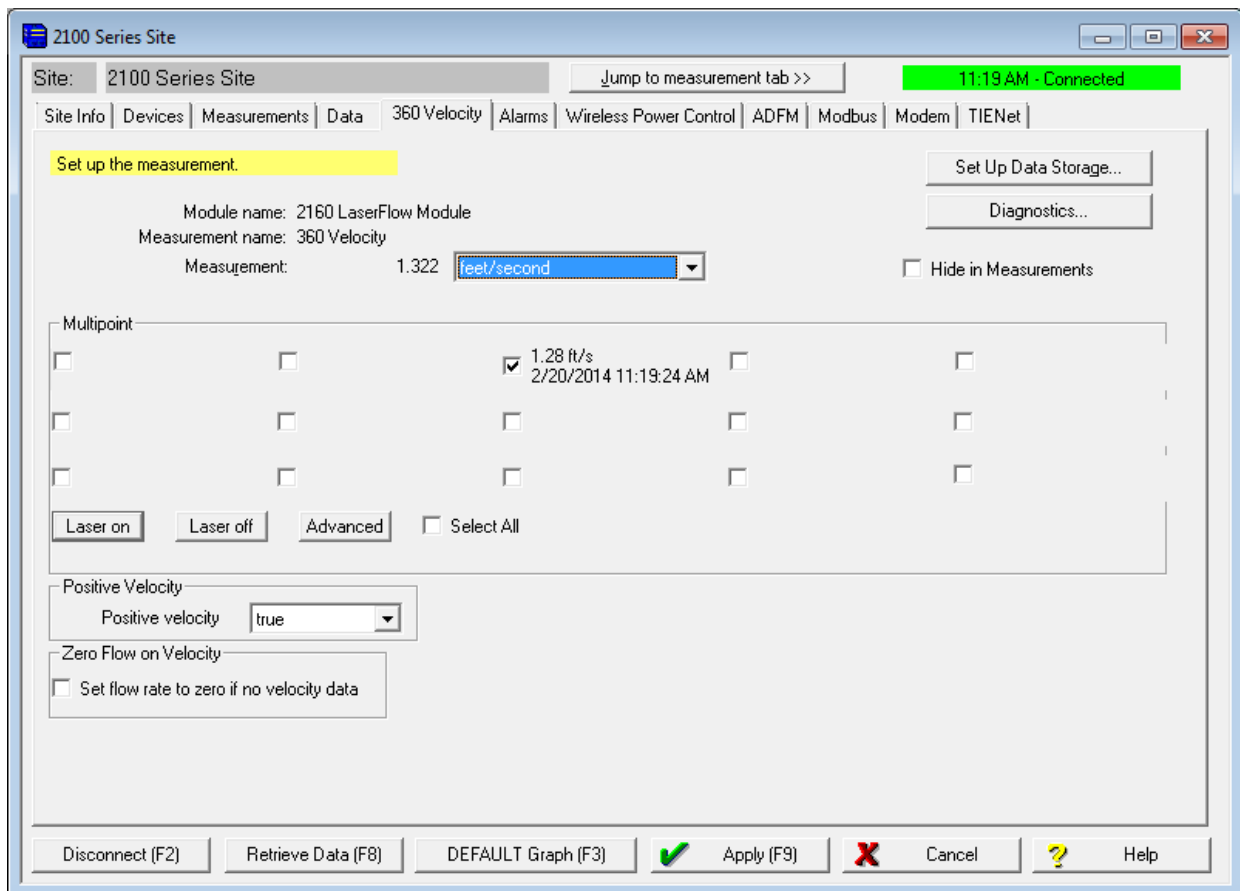

Figure 4-7 360 Velocity Measurement tab in Flowlink

4.2.3 Advanced Settings

The LaserFlow Ex Advanced Settings are pre-programmed into the sensor. However, if your application requires the any custom configuration, the “**Advanced**” button opens the Velocity Coefficients window (refer to Figure 4-8).

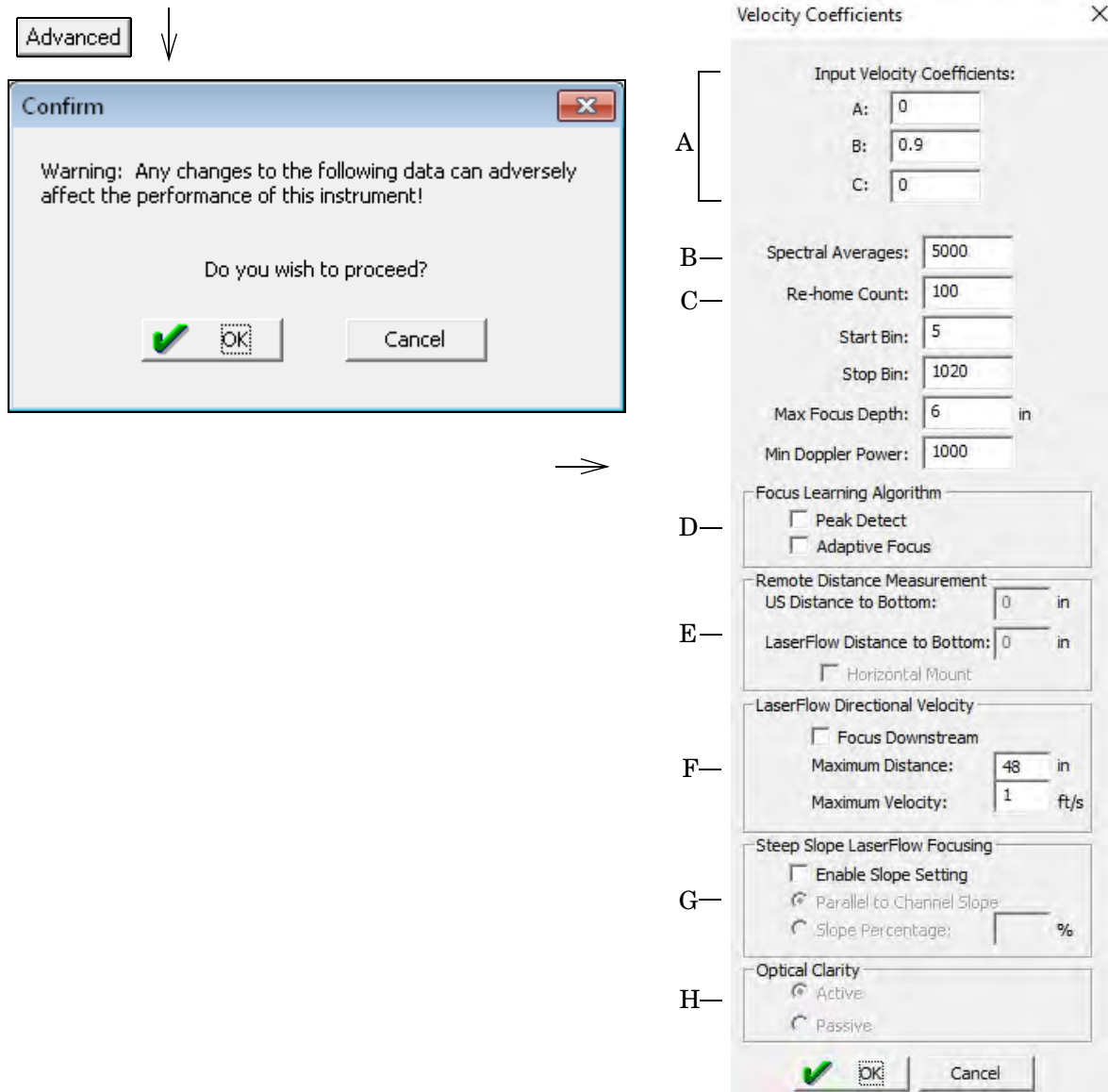
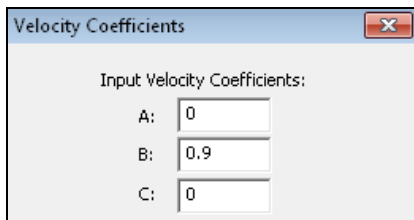

Figure 4-8 360 Velocity Tab: Advanced settings



A - Input Velocity Coefficients

Input Velocity Coefficients – The relationship of the three Input Velocity Coefficients A, B and C can be expressed as:

$$\bar{V} = A (\text{offset}) + B * (\text{Measured Velocity}) + C * (\text{Measured Velocity})^2$$

Coefficient A is an additive offset value to correct the Measured Velocity for any additive bias. The value for A must be expressed in units of meters/second. The default is “0”.

Coefficient B is a multiplicative scalar for correcting the Measured Velocity for any linear multiplicative bias. The value for B is unitless. The default is “0.9”.

Coefficient C is another scalar to correct the Measured Velocity for any nonlinear bias. The value for C must be expressed in units of seconds/meter, so that the resulting value for the Reported Velocity Reading will be in units of meters/second. The default is “0”.



Spectral Averages: 5000

B - Spectral Averages

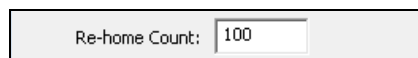

Re-home Count: 100

C - Re-home Count

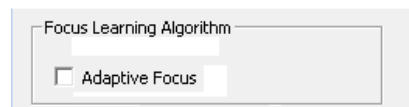

Focus Learning Algorithm
 Adaptive Focus

D - Focus Learning Algorithm

Spectral Averages – The value for Spectral Averages may be used to reduce sampling time and increase Doppler power under certain flow conditions. The default is “5000”. If the flow is consistently turbulent or erratic and causing low Doppler power or velocity dropouts, enter a lower value, such as 3000. This will decrease sampling time and reduce noise in the Doppler signal caused by fluctuating velocity in the flow stream.

Re-home Count – For testing purposes only. For more information, contact Environmental Products Support.

Focus Learning Algorithm – Adaptive Focus enables the LaserFlow Ex module to scan above and below the standard focus point, then adjust the focus to the point with the best signal strength. To enable Adaptive Focus functionality, select the “**Adaptive Focus**” check box.

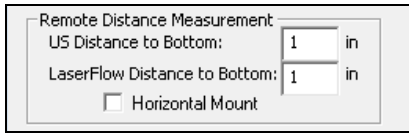

E - Remote Distance Measurement

Remote Distance Measurement – The Remote Distance Measurement options are active only when the LaserFlow Ex module is connected to the TIENet 310 remote ultrasonic sensor.

The **US Distance to Bottom** is the distance (e.g., inches) from the 310 remote ultrasonic sensor to the bottom of the channel. See Figure 4-9. Units of measurement are based on user settings.

Note

When using the horizontal sensor mount bracket, the US Distance to Bottom is measured from the bottom tip of the horizontal sensor mount bracket to the bottom of the channel. See Figure Figure 4-10.

The **LaserFlow Ex Distance to Bottom** is the distance (e.g., inches) from the bottom of the LaserFlow Ex sensor the bottom of the channel. Units of measurement are based on user settings.

Select the “**Horizontal Mount**” check box if using the optional horizontal sensor mount bracket. See Figure 4-10.

Note

Add default values for remote distance when integral.

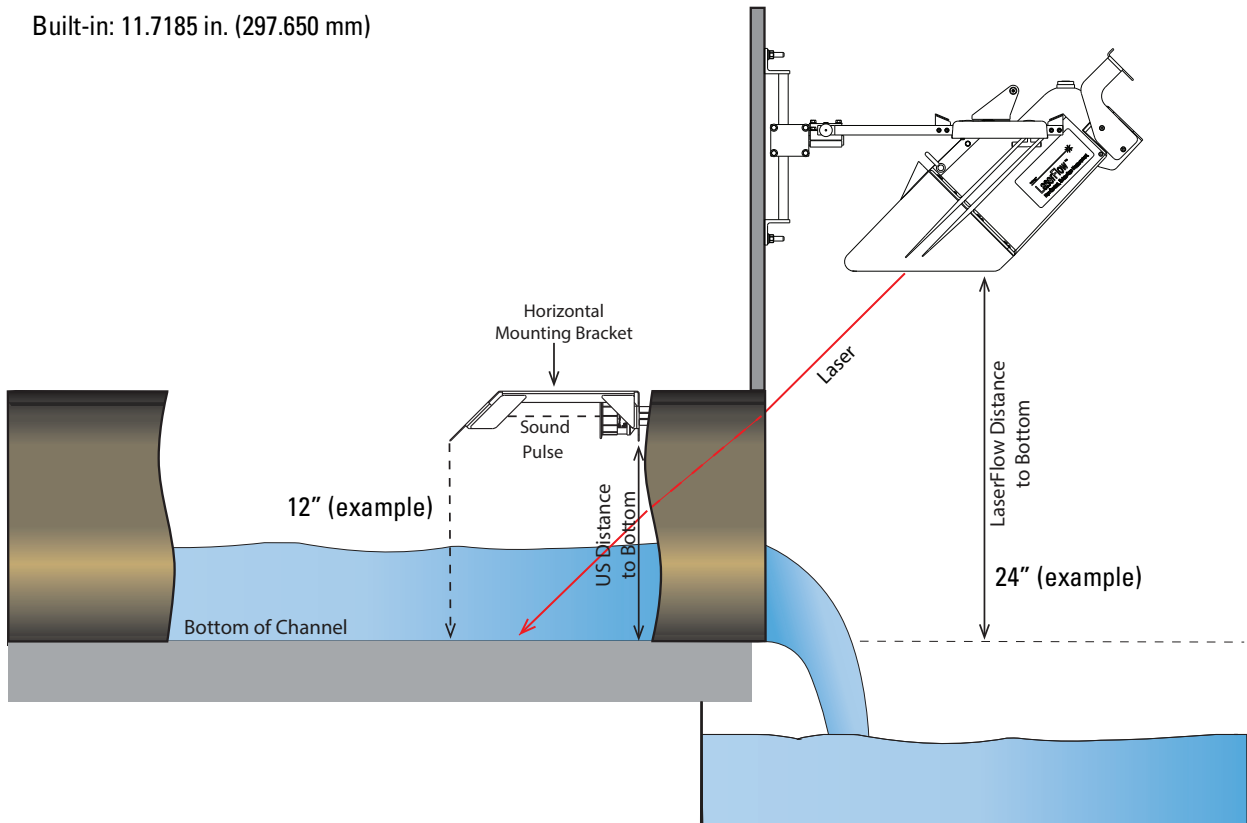

Figure 4-9 Remote distance measurement with the 310 remote ultrasonic sensor

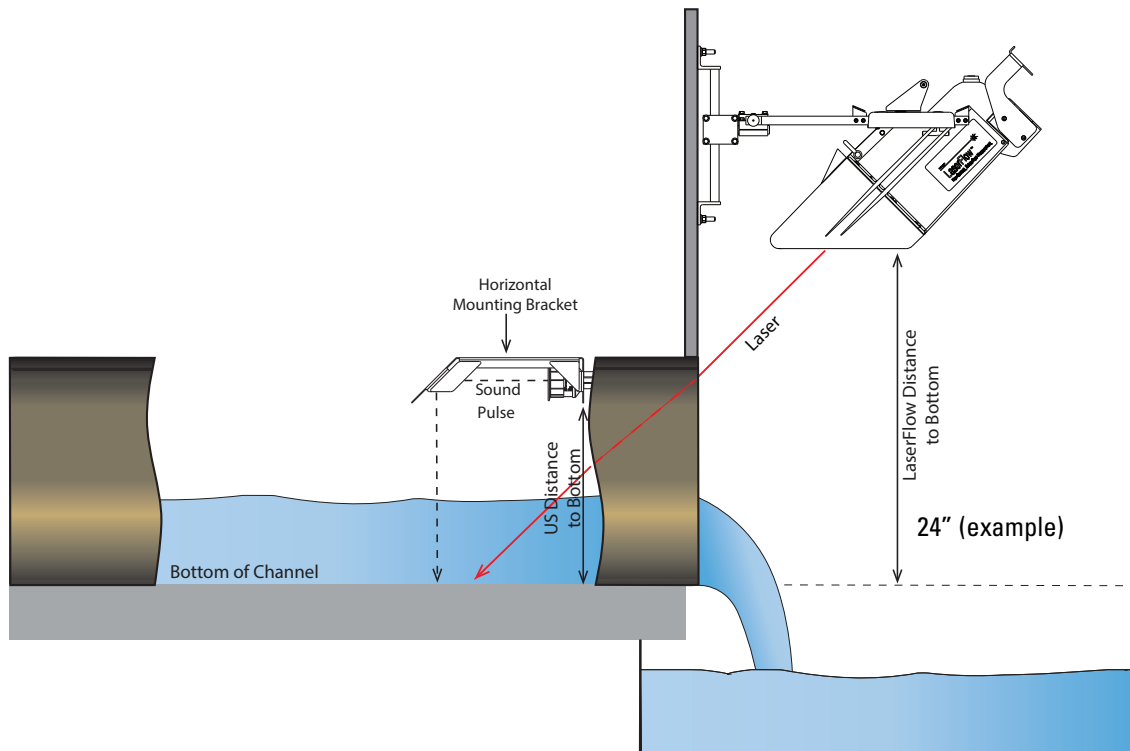
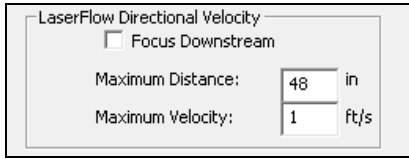
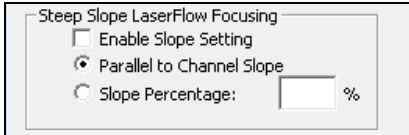

Figure 4-10 Remote distance measurement with the 310 remote ultrasonic sensor and horizontal sensor mount bracket



F - LaserFlow Ex Directional Velocity



G - Steep Slope LaserFlow Ex Focusing

LaserFlow Ex Velocity – The LaserFlow Ex Velocity options are active only when the Positive Velocity option is “false”.

Select the “**Focus Downstream**” check box when the LaserFlow Ex sensor is pointed downstream.

Steep Slope LaserFlow Ex Focusing – If the sensor is on a slope greater than 1%, select the “**Enable Slope Setting**” check box. By default, this option is disabled.

If the sensor is parallel to the channel slope, select “**Parallel to Channel Slope**”. Measure from the front of the sensor carrier to the bottom of the channel. Then measure from the back of the sensor carrier to the bottom of the channel. Ensure the distance is equal. Adjust the sensor carrier as necessary. See Figure 4-11. By default, this option is enabled.

If the slope of the pipe is known, mount the sensor level with the Earth, using the bubble level mounted on the top of the sensor and then enter the **Slope Percentage** in the field. A positive slope value is used when the laser beam is pointed upstream. See Figure 4-12. By default, this option is disabled.

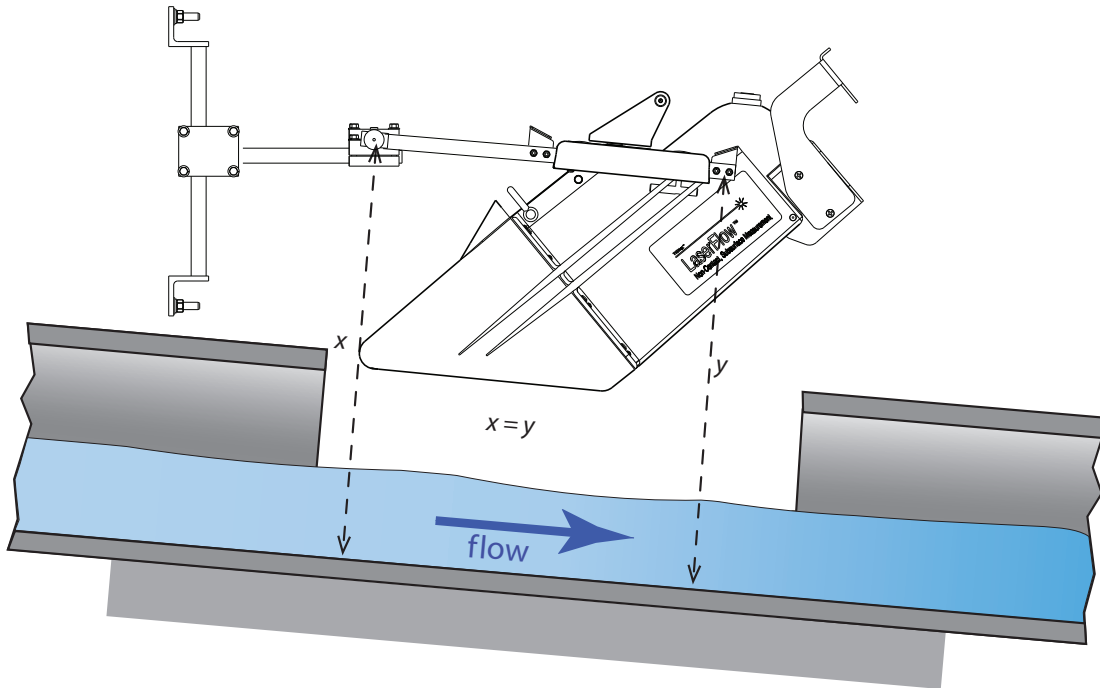

Figure 4-11 LaserFlow Ex placement using Parallel to Channel Slope option

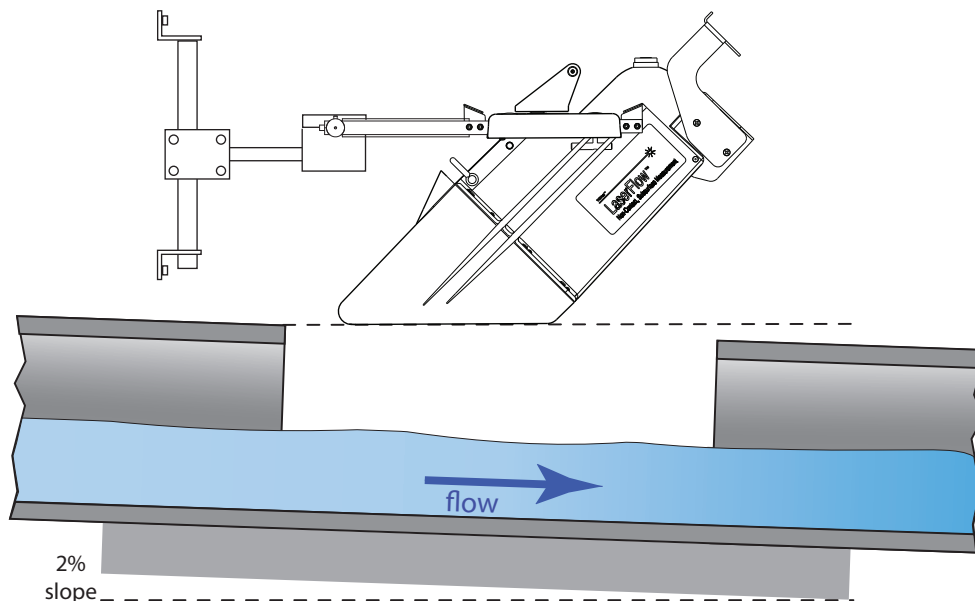
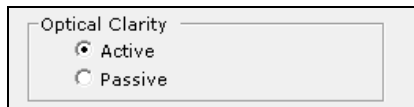

Figure 4-12 LaserFlow Ex placement using Slope Percentage option



H - Optical Clarity

Optical Clarity – Sense voltage detects condensation on the window of the LaserFlow Ex sensor. When the sense voltage is greater than 100 mV, the defogger is activated. The defogger is enabled from 1 to 5 minutes, depending on the severity of the fog.

Note

In locations with severe fogging potential, Teledyne ISCO recommends increasing battery capacity or monitoring the site more frequently.

To enable Optical Clarity, click “**Active**”. To disable Optical Clarity, click “**Passive**”. The default is “Active”.

Table 4-1 Default Advanced Settings

LaserFlow Hardware Revisions				
	A2	C2	C6	X0
Input Velocity Coefficients:				
A:	0.0	0.0	0.0	0.0
B:	0.9	0.9	0.9	0.9
C:	0.0	0.0	0.0	0.0
Spectral Averages:	5,000	5,000	5,000	5,000
Re-home Count:	100	100	100	100
Start Bin:	15	7	7	7
Stop Bin:	1,020	1,020	1,020	1,020
Max Focus Depth:	0.1524 m	0.1524 m	0.1524 m	0.1524 m
Min Doppler Power:	1,000	1,000	1,000	1,000
Focus Learning Algorithm				
Peak Detect	Un-checked	Un-checked	Un-checked	Un-checked
Adaptive Focus	Un-checked	Un-checked	Un-checked	Un-checked
Remote Distance Measurement				
US Distance to Bottom	N/A	N/A	0.0 m	0.29765 m ^{note 1}
LaserFlow Distance to Bottom	N/A	N/A	0.0 m	0.0 m
Horizontal Mount	N/A	N/A	Un-checked	Un-checked
LaserFlow Directional Velocity				
Focus Downstream	Un-checked	Un-checked	Un-checked	Un-checked
Maximum Distance	1.2192 m	1.2192 m	1.2192 m	1.2192 m
Maximum Velocity	0.3048 m/s	0.3048 m/s	0.3048 m/s	0.3048 m/s
Steep Slope LaserFlow Focusing				
Enable Slope Setting	Un-checked	Un-checked	Un-checked	Un-checked
Parallel to Channel Slope	Checked	Checked	Checked	Checked
Slope Percentage	Un-checked	Un-checked	Un-checked	Un-checked
Optical Clarity				
Active	Checked	Checked	Checked	Checked
Passive	Un-checked	Un-checked	Un-checked	Un-checked

Note 1 –If the LaserFlow Ex was used in a remote ultrasonic configuration and now will be used in the built in configuration, set the US Distance to Bottom value to 0.29765 m and the LaserFlow Distance to Bottom to zero.

4.3 Sensor Positioning and Adjustment

To set the initial level values, refer to Sections 4.2.1.

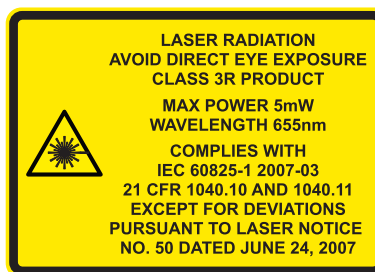

4.3.1 Centering the LaserFlow Ex Sensor

Proper positioning of the LaserFlow Ex sensor is critical for optimal velocity measurement. In center position, the laser beam must strike the flow stream precisely in the center.

The beam automatically moves to the top center position.

Laser on

Select the “**Laser on**” button and click the “**Apply**” button. This will keep the laser beam on continuously for 10 minutes or until the “**Laser off**” button is clicked, allowing the beam to be used for fine-tuning the sensor’s position.

Note

When sensor positioning is completed, securely tighten all mounting hardware.

4.3.2 Laser Velocity Measurement Point Selection

Once the LaserFlow Ex sensor is installed over the flow stream, some installations may only require the center laser position for velocity measurement.

For installations requiring multiple measurement points, determine which points will be used. To do so, activate the 3 points and wait for all of them to display their readings. This process may take up to 15 minutes.

Each point will display a velocity reading and time stamp, or “Invalid.” Deselect “Invalid” and undesired points. The fewer points selected, the less time required to complete one velocity measurement.

Select the “**Select All**” check box to activate the 3 points, then click the “**Apply**” button.

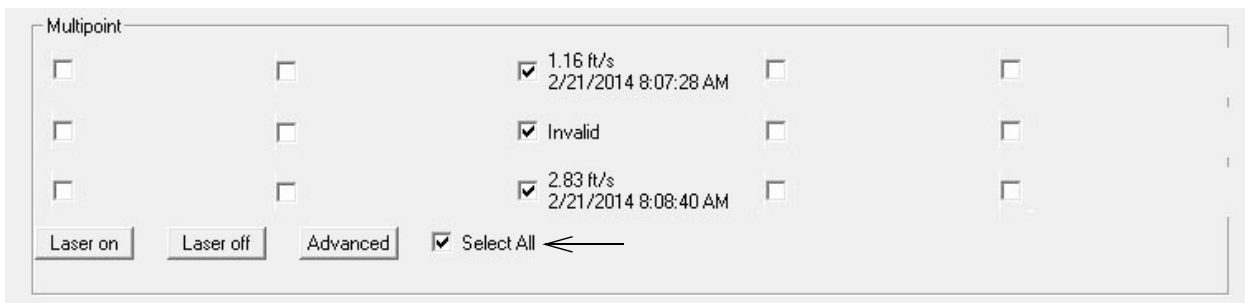

Deselect “Invalid” and undesired points, then click the “**Apply**” button.

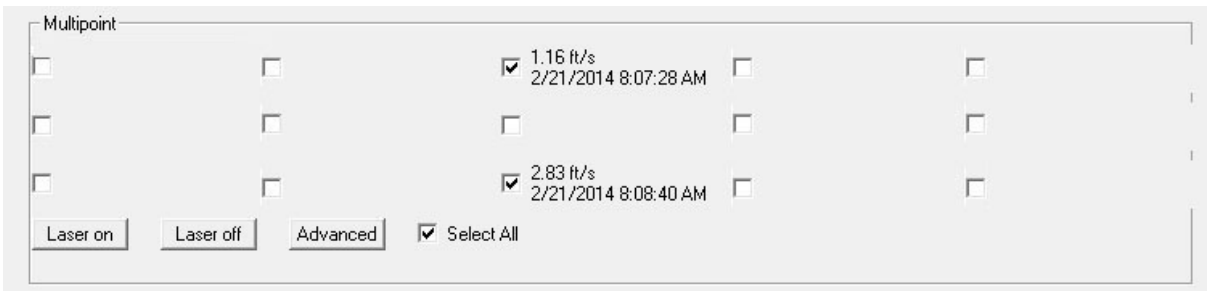

Figure 4-13 Selection of velocity measurement points

TIENet® 360 LaserFlow Ex® Velocity Sensor

Section 5 Maintenance and Optional Kits

5.1 Maintenance

The following tables are recommended maintenance checks to ensure proper operation. As site conditions may vary, increase the frequency of inspections as needed.

Table 5-1 Recommended Maintenance (Accessible Locations)

Action	Recommended Frequency	Location
Check Ultrasonic level sensor for obstructions (e.g., spider webs, debris)	Monthly	On-site
Check Horn for obstructions (e.g., spider webs, debris)	Monthly	On-site
Ensure suitable alignment - check x-axis (roll) and y-axis (pitch)	Weekly	Via Flowlink application or Signature flowmeter
Check Doppler Power and assess historical trend	Weekly	Via Flowlink application or Signature flowmeter
Check Ultrasonic Signal and assess historical trend	Weekly	Via Flowlink application or Signature flowmeter

Table 5-2 Recommended Maintenance (Difficult-to-Access Locations)

Action	Recommended Frequency	Location
Check Ultrasonic level sensor for obstructions (e.g., spider webs, debris)	Every 6 months or following surcharge event	On-site
Check Horn for obstructions (e.g., spider webs, debris)	Every 6 months or following surcharge event	On-site
Ensure suitable alignment - check x-axis (roll) and y-axis (pitch)	Weekly	Via Flowlink application or Signature flowmeter
Check Doppler Power and assess historical trend	Weekly	Via Flowlink application or Signature flowmeter
Check Ultrasonic Signal and assess historical trend	Weekly	Via Flowlink application or Signature flowmeter

5.2 Firmware Updates

When firmware updates become available, they can be downloaded from www.isco.com or via email from the factory.

5.2.1 With Signature flowmeter

The TIENet device's firmware is updated via the USB port on the front panel of the Signature flowmeter. Step-by-step instructions for updating the firmware can be found in Section 2 of the Signature user manual.

5.2.2 With 2160 LaserFlow Module

The TIENet device's firmware is updated via the "Update Isco Instrument Software" tool from Flowlink for the 2160 module. Step-by-step instructions for updating the firmware can be found in the Help text of the update application.

5.3 Cleaning the Sensor Housing

The LaserFlow Ex sensor's outer housing and ultrasonic transducer can be cleaned with warm water, mild soap, and a soft, lint-free cloth. Do not spray water on the laser window; install the protective window cap prior to cleaning.

▲ CAUTION

Never use ordinary cloth or abrasives to clean the LaserFlow Ex as they may cause scratches.

▲ CAUTION

Be sure the protective window cap is installed during cleaning, storage, or shipment (refer to Section 1.6.1).

5.4 Accessing the LaserFlow Ex's Nose Piece

Several procedures for maintenance and options require accessing the interior of the sensor by separating the nose piece from the body, and subsequent reassembly. Refer back to this section when performing these procedures.

▲ WARNING

Disconnect power from the LaserFlow Ex sensor before opening the sensor housing.

Tools required

- #2 Phillips straight screwdriver less than 4" (right-angled if available)

5.4.1 Removing the Nose Piece

The screws that attach the nose piece to the body are difficult to access with a straight screwdriver, being somewhat obstructed by the mounting block.

1. Remove the 6 large Phillips screws on the LaserFlow Ex nose piece, and separate the nose from the body. **Do not remove any other screws.**

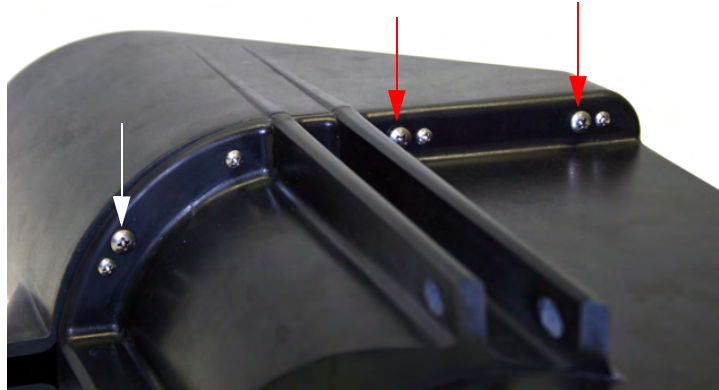

Figure 5-1 Remove large screws and nose piece (3 on each side)

5.4.2 Replacing the Nose Piece

1. Fasten the sensor back together by cross-tightening the 6 large Phillips screws in diagonal order until the two sections are flush against each other.

▲ CAUTION

When reinstalling all self-tapping screws, avoid stripping the plastic threads. First seat each screw in its hole and, with light downward pressure, rotate the screw counter-clockwise until it falls into its thread groove with a "click". Then tighten the screw.

2. If applicable, reinstall the mounting block, ensuring that both flat and split washers are included.

Side cross-pin
(1 of 2)



Center cross-pin

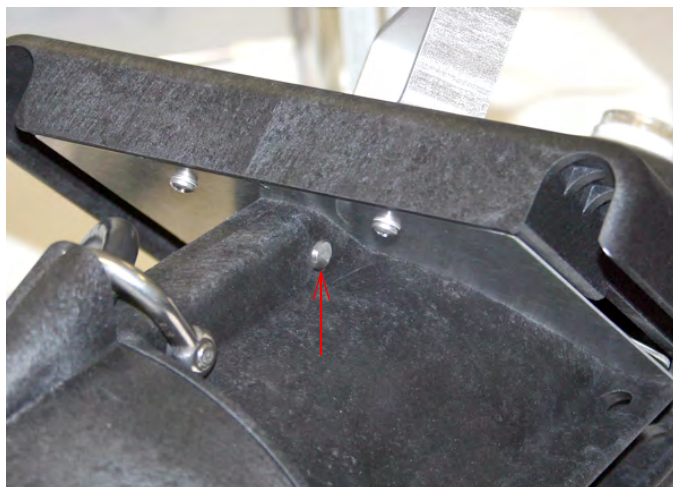

Figure 5-2 Location and orientation of cross-pins for mounting block installation

5.5 Velocity Readings and the Laser Window

Invalid or inconsistent velocity readings may indicate debris or moisture condensation on the window protecting the laser.

The laser window is crucial for focusing and should never be touched. Smudging or scratches can degrade the performance of the sensor. **For these reasons, cleaning the window is NOT recommended unless absolutely necessary.**

If cleaning must be performed, follow the instructions provided in Section 5.6.

5.6 Cleaning the Laser Window

The laser window is crucial for focusing and should never be touched. Smudging or scratches can degrade the performance of the sensor. **For these reasons, cleaning the window is NOT recommended unless absolutely necessary.**

CAUTION

Never touch the laser window. Never use ordinary cloth or water to clean the surface of the laser window.

Items required for cleaning

- Pre-packaged, pre-IPA-moistened, single-use, lint-free tissue, such as Zeiss Lens Cleaning Wipes or Bausch & Lomb Sight Savers®¹ Pre-Moistened Lens Cleaning Tissues.
- Kimwipes®² dry tissues
- Rain-X®³ Original Glass Treatment

CAUTION

Never moisten the tissue with IPA or other solution *after* removing it from its package.

Procedure

You must remove the nose piece to clean the window. Instructions for opening and reassembling the LaserFlow Ex nose piece are provided in Section 5.4 *Accessing the LaserFlow Ex's Nose Piece*.

WARNING

Disconnect power from the LaserFlow Ex sensor before opening the sensor housing.

1. Remove the folded tissue from its package and use the corners to lightly brush any abrasive material from the surface.
2. Unfold the tissue and gently clean the surface with downward strokes only, **keeping the tissue between your finger and the glass at all times.**

-
1. Sight Savers® is a registered trademark of Bausch & Lomb, Inc.
 2. Kimwipes® is a registered trademark of Kimberly-Clark Corporation.
 3. Rain-X® is a registered trademark of Illinois Tool Works, Inc.

3. Examine the window closely under good lighting from all directions to ensure there are no smudges, streaks, or film on the surface.
If the window is smudged, streaked, or still dirty, get a fresh pre-packaged tissue and repeat.
4. Next, fold a clean, dry Kimwipe tissue four times to reinforce its thickness, and gently clean the window surface with downward strokes only, **keeping the tissue between your finger and the glass at all times.**
5. Examine the window closely under good lighting from all directions to ensure there are no smudges, streaks, or film on the surface.
If the window is smudged, streaked, or still dirty, get a fresh pre-packaged tissue and repeat.
6. Fold a fresh Kimwipe tissue as previously described and spray the closed end of it with Rain-X.

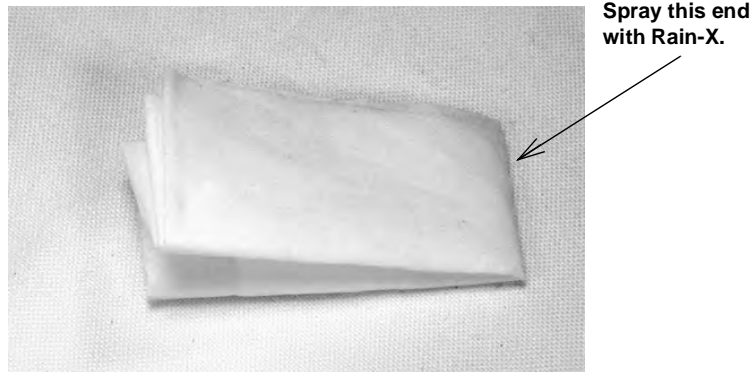

Figure 5-3 Cleaning the laser window: Moisten Kimwipe tissue w/ Rain-X

7. Apply the Rain-X to the entire window surface using downward strokes only.
8. After allowing 30 minutes for the Rain-X treatment to dry, wipe the window with another dry Kimwipe tissue, as described in step 4.
9. Carefully examine the window as previously described, and continue polishing the surface with fresh dry tissues until no streaks or film are visible.

Reassemble the nose piece, following the steps provided in Section 5.4.2 *Replacing the Nose Piece.*

5.7 Installing the Remote TIENet 310 Ultrasonic Level Sensor

Refer to the TIENet 310 Ultrasonic Level Sensor Installation and Operation Guide for details.

TIENet® 360 LaserFlow Ex® Velocity Sensor

Appendix A Replacement Parts

A.1 Replacement Parts Diagrams and Listings

Replacement parts can be purchased by contacting
Teledyne ISCO's Customer Service Department.

Teledyne ISCO
Customer Service Department
P.O. Box 82531
Lincoln, NE 68501 USA

Phone: (800) 228-4373
(402) 464-0231
FAX:(402) 465-3022

E-mail: isco.orders@teledyne.com

A.2 LaserFlow Ex Sensor 360 LaserFlow Sensor Replacement Parts



604367001
Replacement LaserFlow Mounting
Handle Kit

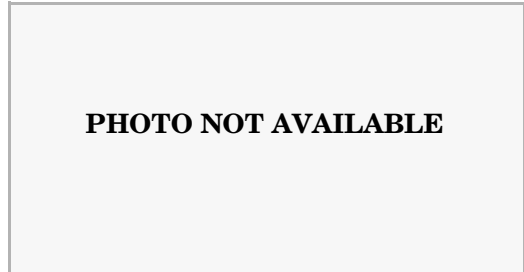

604363014
Horn used on LaserFlow Sensor (black)



609004470
Replacement Small Parts Package Kit
for LaserFlow



202100669
O-Ring (0.699 I.D., 0.079 Cross Section)

Vertical Mounting Bracket Kit



609004471
Replacement LaserFlow Vertical
Mounting Components Kit for
Permanent Wall Mounting



231115921
Hex Machine Screw
(1/4-20 x 1-1/4 inch long)



604364037
Anchor Studs with Lock Washers used on
LaserFlow Mounting Bracket

Horizontal Tube Coupler Parts



604363026
Coupling Tube used on LaserFlow
Mounting Bracket



604363036
Extended Coupling Tube used on
LaserFlow Mounting Bracket



605324154
24" Laser Mount Coupling Tube

Horizontal Mount Bracket Parts Kit



609004472
Replacement LaserFlow Horizontal
Mounting Components Kit for Permanent
Wall Mount



231115921
Hex Machine Screw
(1/4-20 x 1-1/4 inch long)

U Tube Mounting Bracket Parts



604364044
Mounting Alignment Tabs with
Hardware Kit

**A.3 Wall Mounting
Hardware**

360 LaserFlow Sensor Temporary Mounting Kits



609004473
Replacement LaserFlow Temporary
Mount Cargo Bar Clamp Kit



60-9004-474
Replacement LaserFlow Temporary
Mount Kit For U Tube Clamp

A.4 Replacement Sensors

TIENet 360 LaserFlow Ex Sensor with Built-in Ultrasonic

LaserFlow Ex Sensor, 10m Unterminated Cable	Call Factory
LaserFlow Ex Sensor, 23m Unterminated Cable	Call Factory
LaserFlow Ex Sensor, cut to length Unterminated Cable	Call Factory

Includes TIENet 310 Ultrasonic Level Sensor

LaserFlow Ex Sensor with Remote 310 Ultrasonic, 10m Unterminated Cable	Call Factory
LaserFlow Ex Sensor with Remote 310 Ultrasonic, 23m Unterminated Cable	Call Factory
LaserFlow Ex Sensor with Remote 310 Ultrasonic, cut to length Unterminated Cable.....	Call Factory

Excludes TIENet 310 Ultrasonic Level Sensor

LaserFlow Ex Sensor with Remote 310 Ultrasonic, 10m Cable w/ TIENet Plug	Call Factory
LaserFlow Ex Sensor with Remote 310 Ultrasonic, 23m Cable w/ TIENet Plug	Call Factory
LaserFlow Ex Sensor with Remote 310 Ultrasonic, cut to length w/ TIENet Plug.....	Call Factory

A.5 Sensor Accessories

LaserFlow Ex Sunshade	Call Factory
-----------------------------	--------------

TIENet® 360 LaserFlow Ex® Velocity Sensor

Appendix B Installation Checklist

B.1 Introduction

This special appendix is to assist you in ensuring that you have all equipment, supplies, and site information readily available prior to going to site for installation.

Print these pages and fill out all relevant information.

Once you have established that all of the items listed here are on hand, take this printout to the site to assist in installation and setup.

B.2 Equipment and Recommended Tools

- LaserFlow Ex Sensor
- 2160 Module or Signature flowmeter
- Flowlink 5.1 Software and Communication Cable
- Power source
- Tape Measure
- Level
- Laptop computer
- Wall Mount Kit, if mounting on wall
 - o 7/16" Open or Socket Wrench
 - o 9/16" Open or Socket Wrench
 - o Hammer Drill
 - o 3/8" Masonry Bit
 - o Hammer
- Temporary Mount Kit, if application is temporary
 - o 7/16" Open or Socket Wrench
- Optional Sensor Retrieval Tool

B.3 Site Information

1. Site Name: _____

2. Meter:

- 2160 Module (Serial Number: _____)
- Signature flowmeter (Serial Number: _____)
- LaserFlow Ex Sensor (Serial Number: _____)
- TIENet Barrier (Serial Number: _____)

3. Meter Location: _____

4. Channel Shape:

- Round
- U-Shaped
- Rectangular
- Trapezoidal
- Elliptical

5. Channel Dimensions:

6. Number of Velocity Points: _____

7. Expected Level (m or ft)

Minimum: _____

Maximum: _____

Average: _____

8. Expected Velocity (m/s or ft/s)

Minimum: _____

Maximum: _____

Average: _____

9. Distance between bottom of sensor & flow at
Maximum Level (m or ft) _____

10. Distance between bottom of
sensor & channel bottom (m or ft): _____

11. Direction sensor is facing:

Upstream

Downstream

12. Site IP Address: _____

13. Call-In Window

Start: _____

Stop: _____

14. Server Push Address: _____

15. Software Revisions

Flowlink: _____(*Help > About Flowlink*)

LaserFlow Ex: _____(*TIENet / Configure*)

2160: _____(*Device Tab*)

Signature: _____(*Menu > Admin > Display Signature Information*)

16. Data Storage Rate: _____

B.4 Recommended Essential Parameters

The following basic parameters are used in almost every measurement site.

In the 2160, parameters are activated in the Jump to Measurements tab.

In the Signature, parameters are activated by going to Hardware Setup > Configure Measurements.

360 Distance	360 Level
360 Velocity	360 X-Axis
360 Y-Axis	360 Ultrasonic Signal
360 Doppler Power	360 Case Temperature
360 Air Temperature	Flow Rate
360 Sense Voltage	For recommended parameters

After programming, Retrieve Data to download initial diagnostic data, to verify that this data will be available if/when needed.

B.5 Site Conditions

LaserFlow Ex with Built-in Sensor: When using the LaserFlow Ex module with the attached sensor, never install the LaserFlow Ex in a free-flowing outfall or in a drop manhole (see Figure B-1).



Figure B-1 Do not install LaserFlow Ex with built-in sensor in a free-flowing outfall or in a drop manhole.

LaserFlow Ex with Remote Ultrasonic Sensor: When using the LaserFlow Ex module with the remote ultrasonic sensor, the LaserFlow Ex sensor can be installed in a free-flowing outfall or in a drop manhole.

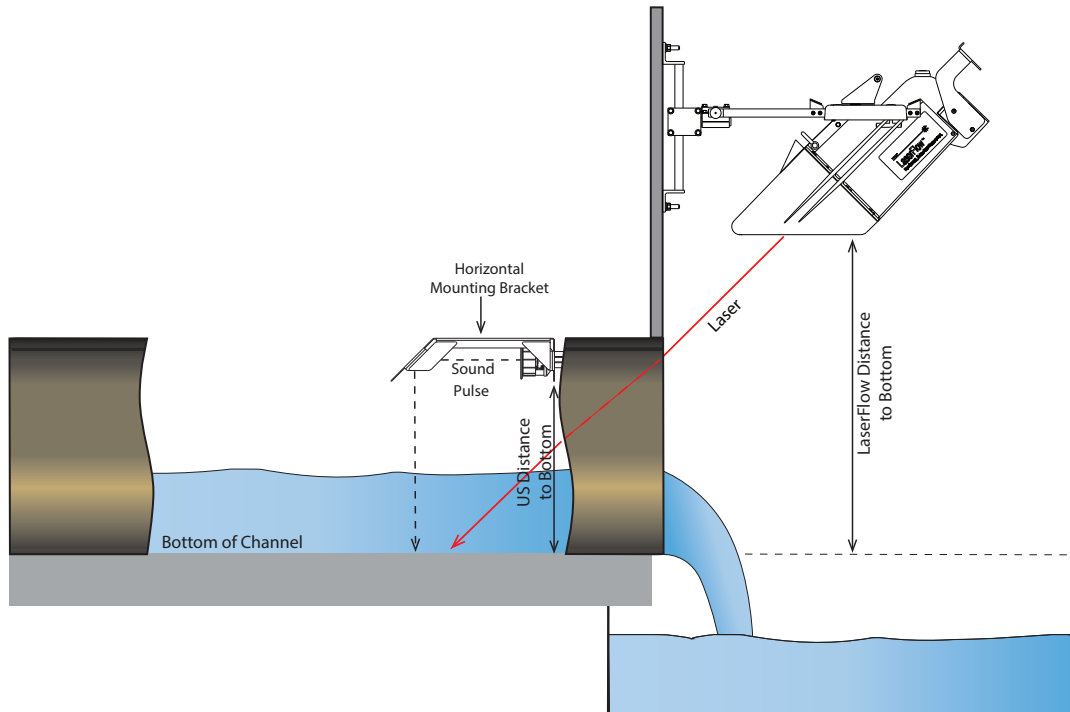

Figure B-2 Correct setup when using the LaserFlow Ex module with remote ultrasonic sensor and horizontal mount bracket

Stream Level – The stream level should be the same at both the laser and ultrasonic measuring points.

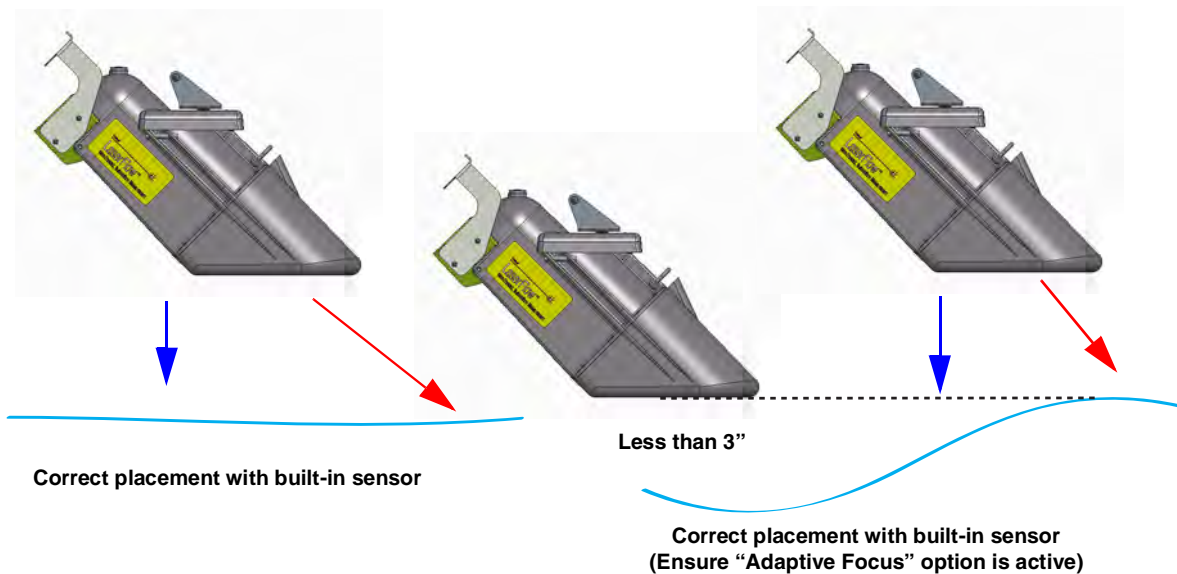

Figure B-3 Placement of LaserFlow Ex with built-in sensor

Note

If the stream level is less than 3" (7.62 cm) when using the LaserFlow Ex with built-in sensor, ensure the Adaptive Focus option is active Figure B-3.

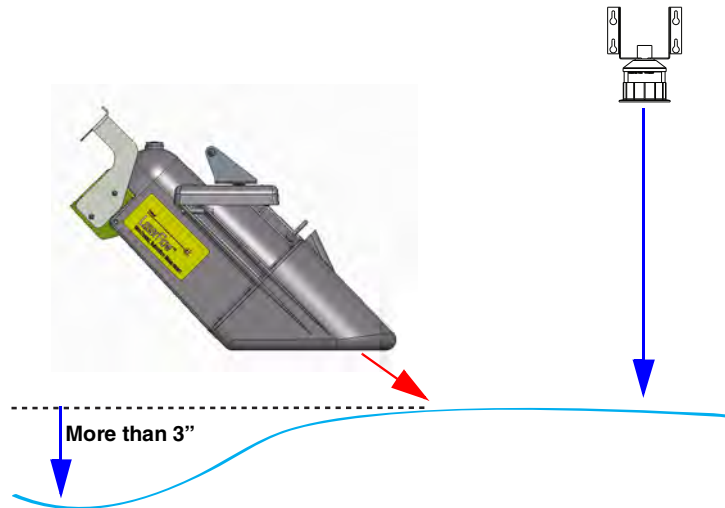

Figure B-4 Placement of LaserFlow Ex with remote ultrasonic sensor

Note

If the laser and ultrasonic measuring points differ at the stream level by more than 3" (7.62 cm), the remote ultrasonic sensor must be used, Figure B-4.

Foam or Steam – Never install the LaserFlow Ex over foam or steam.



B.6 Sensor Positioning

Straight Runs – For best performance, place the sensor in the straightest possible run, at a minimum of 5 channel diameters downstream and 2 channel diameters upstream from a bend or divergence or convergence of channels.

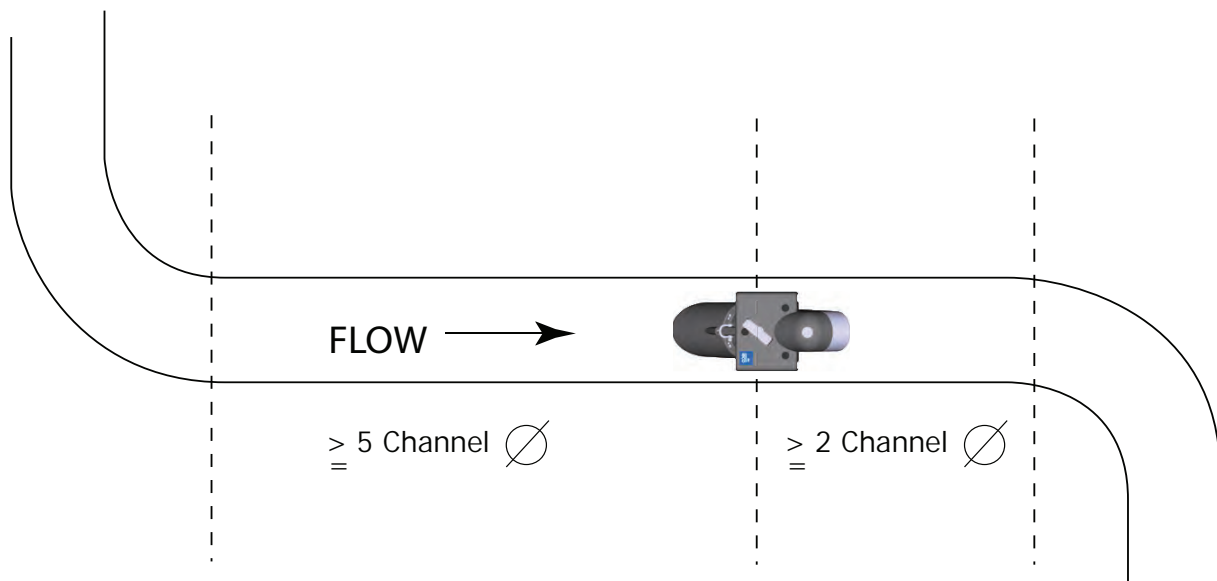

Center of Pipe – Center the LaserFlow Ex (and middle laser beam) relative to the pipe walls.

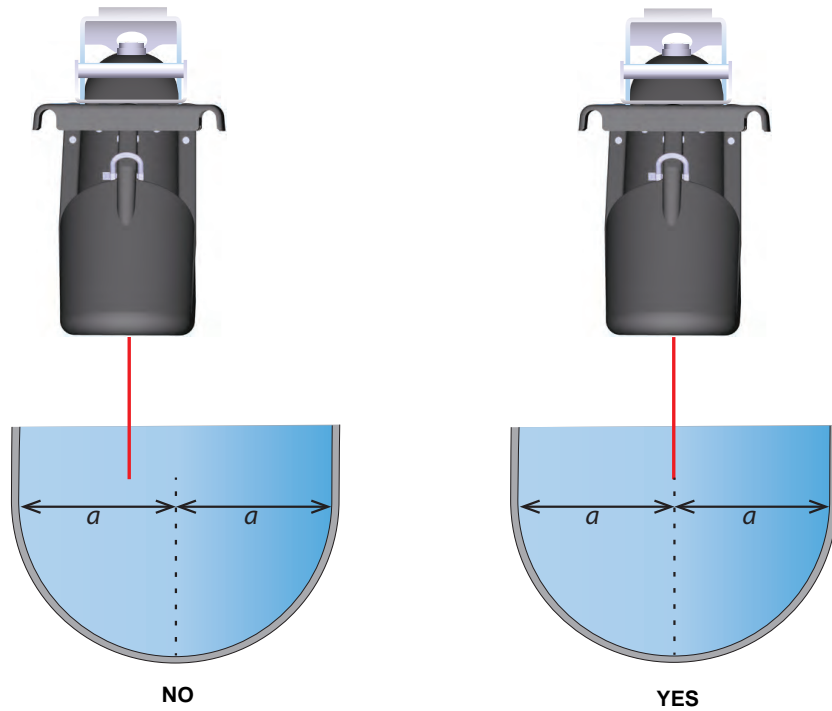

Parallel w/ Flow – Install the LaserFlow Ex parallel with the flow.
Never install it at an angle, or perpendicular, to the flow.

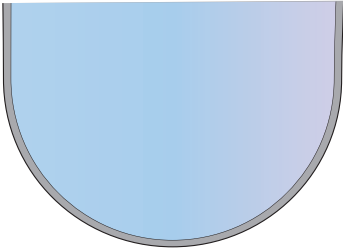
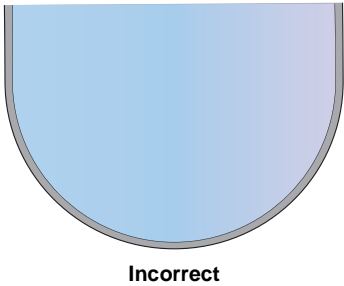
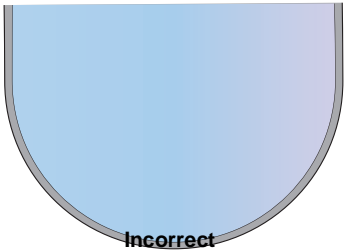
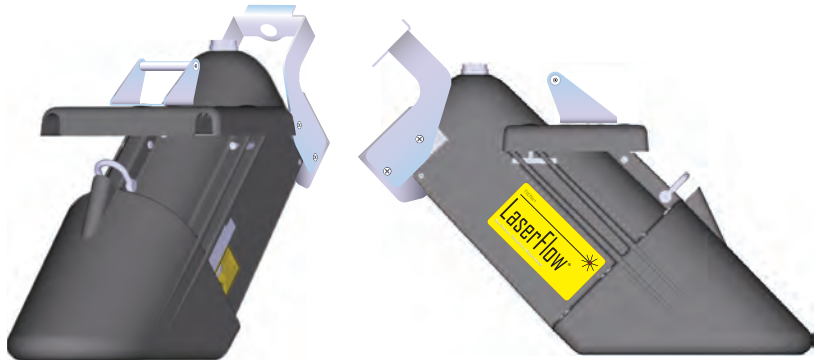

TIENet® 360 LaserFlow Ex® Velocity Sensor

Appendix C Velocity Error Codes

C.1 Introduction

Erroneous flow data can result from a number of factors. The LaserFlow Ex system provides numbered error codes associated with the 360 Velocity data to assist in troubleshooting.

If using the 2160 LaserFlow Ex module, error codes are viewable using Teledyne ISCO Flowlink® software. If using the Signature flowmeter, error codes are viewable in the bottom panel of the display. Definitions of the error codes are provided in Table C-1. For further assistance, contact the factory.

C.2 Importing Data Dump (.ddp) Files (Signature Only)

Flow data can be downloaded from the Signature flowmeter onto a USB flash drive in the form of a .ddp (Data Dump) file.

To download the data:

1. Connect a flash drive to the USB port on the front panel of the Signature flowmeter. From the USB Options menu, select Retrieve Data.
2. Select “All data” or specify a start date or date range, and press NEXT. The data will be stored on the connected flash drive in the “ISCO” folder.
3. Connect the flash drive to a computer with Flowlink installed.
4. Launch the Flowlink application.
5. Copy the file using one of the methods below:
 - a. Select File > Import. When the import window appears, browse to the folder containing the desired .ddp file. Select the file and click Open.
 - b. Select “Signature Data Transfer” from the File menu and then browse to the appropriate folder.

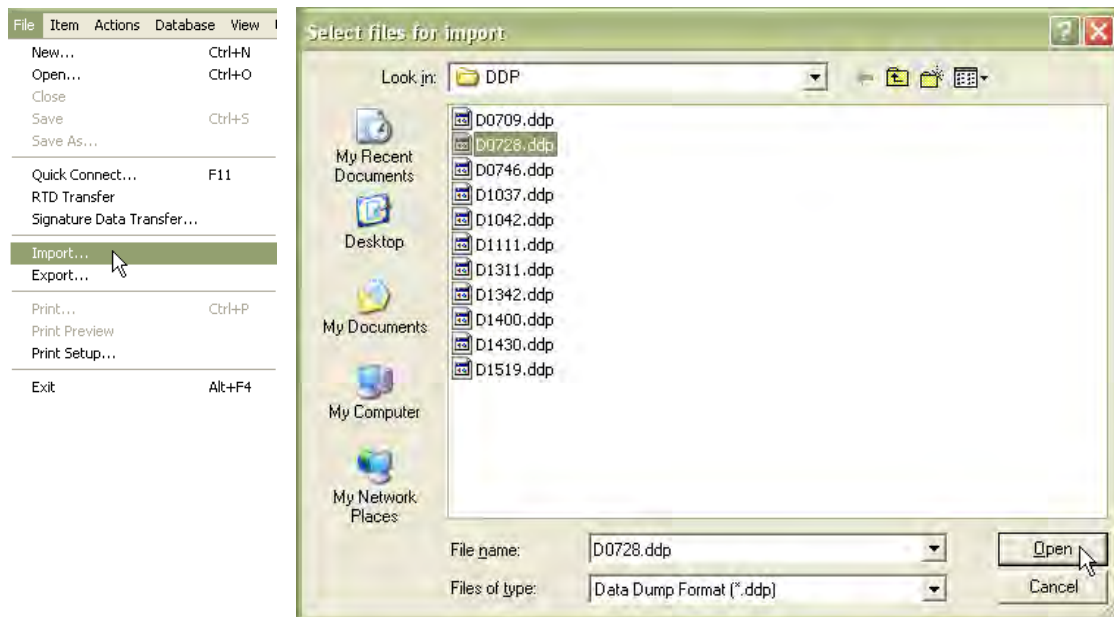

Figure C-1 Signature flow data: Selecting the .ddp file(s)

A progress window will appear, displaying the filename, site name, device type, number of data types in the site file, and progress of the download.

- When the two progress bars have completed, click Done to close the window.

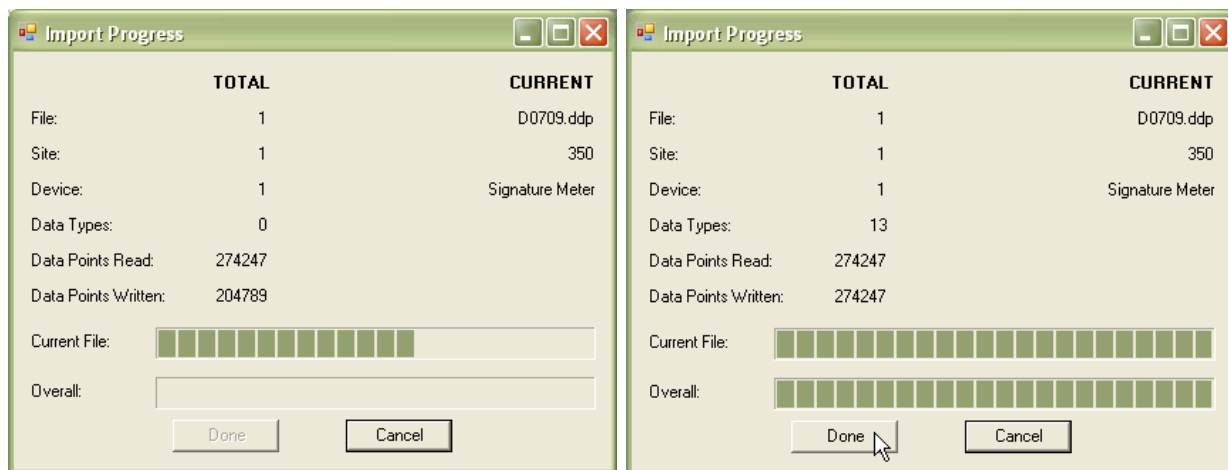



Figure C-2 Signature flow data: Importing the .ddp file

Upon completion, a new site file will appear in the Flowlink workspace.

C.3 Viewing Velocity Error Codes in Flowlink

In order to view error codes for velocity readings:

1. In the Flowlink workspace, double-click the 360 Velocity data set. When the graph appears, click the Table View button. 
2. When the table appears, click the Edit/View button. 

Any error codes will appear in the 360 Velocity column following the words “No Data.” Definitions of the error codes are provided in Table C-1.

Date/Time	360 Velocity(m/s)	Edited 360 Velocity(m/s)
10/4/2012 1:45:00 PM	0.621	0.621
10/4/2012 2:00:00 PM	0.601	0.601
10/4/2012 2:15:00 PM	2.251	2.251
10/4/2012 2:30:00 PM	2.154	2.154
10/4/2012 2:45:00 PM	No Data: 1	2.154
10/4/2012 3:00:00 PM	1.897	1.897
10/4/2012 3:15:00 PM	No Data: 1	0.694
10/4/2012 3:30:00 PM	5.195	5.195
10/9/2012 10:00:00 AM	No Data: 7	0.000
10/9/2012 10:15:00 AM	No Data: 7	0.000

Error codes

Figure C-3 Identifying error codes in the 360 Velocity data set

Error Code	Meaning	Possible Solutions
1: Low Signal Power Error	No laser Doppler signal peak or sufficient strength is found. Minimum is 1000.	Ensure the protective window cap is removed. Refer to Section 1.6.1 Protective Window Cap. Ensure the location of the laser is correct. Verify the distance is 0 to 10 ft from the bottom of the sensor to the flow stream. Ensure the Y-axis (pitch) is accurate (greater or equal to 45°).
2: Flow Direction Error	An error occurred while determining flow direction. This error displays only if the “Positive Velocity” option is set to “true” in the Flowlink application.	If velocity is frequently below 0.1 m/s (0.3 ft/s), the LaserFlow Ex will not be able to determine the flow direction.

Table C-1 Definitions of 360 Error Codes

Error Code	Meaning	Possible Solutions
3: Ultrasonic Read/Level too Low Error	An error occurred during an ultrasonic reading. This includes communication errors with the ultrasonic sensor or the level is below the "minimum level for velocity" threshold.	Ensure the blanking distance is correct. Refer to Section 3.2 Measurement Setup. Ensure the placement of the sensor is accurate. Refer to Section 2.5.3 Sensor Positioning and Requirements. Verify there is no foam, steam, or extreme turbulence.
4: Noisy Doppler Signal Error	The DSP detected a noise level in the doppler signal that is higher than the calibrated noise threshold.	Contact factory.
5: Focus Error	An error occurred while focusing the laser.	Contact factory.
6: Digital Signal Processor (DSP) Communication Error	An error occurred during communication with the DSP.	Contact factory.
7: Sensor not seen	Communication failed between flowmeter and sensor. This could be due to the sensor being disconnected, losing power, etc.	Ensure the sensor is connected to the flowmeter. Ensure the input voltage is 9V (minimum). Verify the battery is connected or charged.

Table C-2 Definitions of 350 Error Codes

Error Code	Meaning	Possible Solutions
1: Measurement Error	Unable to generate valid velocity data set.	Contact factory.
3: Velocity Filter Error	An error occurred while setting the filter clock.	Ensure there are uniform flow conditions at sensor location.
5: Velocity Gain Error	Unable to set gain after maximum attempts.	Ensure there is no debris on the sensor.
6: Level too Low error	The absolute level is too low to attempt velocity measurement.	Place sensor in flow with at least 1" deep. Set storage of velocity to be secondary based on depth of 1".
7: Timeout/Quality Error	Measurement timed out or did not meet measurement quality requirements.	Contact factory.

TIENet® 360 LaserFlow Ex® Velocity Sensor

Appendix D Material Safety Data Sheets

This appendix provides Material Safety Data Sheets for the desiccant used by the TIENet 360 LaserFlow Ex Sensor.

Teledyne ISCO cannot guarantee the accuracy of the data. Specific questions regarding the use and handling of the products should be directed to the manufacturer listed on the MSDS.

SORB-IT® is a registered trademark of N. T. Gates Company.

[101 Christine Drive](#)
[Belen, New Mexico 87002](#)
[Phone: \(505\) 864-6691](#)
[Fax: \(505\) 861-2355](#)



MATERIAL SAFETY DATA SHEET -- September 28, 1998
 SORB-IT®
 Packaged Desiccant

SECTION I -- PRODUCT IDENTIFICATION

Trade Name and Synonyms:	Silica Gel, Synthetic Amorphous Silica, Silicon, Dioxide
Chemical Family:	Synthetic Amorphous Silica
Formula:	SiO ₂ .x H ₂ O

SECTION II -- HAZARDOUS INGREDIENTS

Components in the Solid Mixture

COMPONENT	CAS No	%	ACGIH/TLV (PPM)	OSHA-(PEL)
Amorphous Silica	63231-67-4	>99	PEL - 20 (RESPIRABLE), TLV - 5	LIMIT - NONE, HAZARD - IRRITANT "

Synthetic amorphous silica is not to be confused with crystalline silica such as quartz, cristobalite or tridymite or with diatomaceous earth or other naturally occurring forms of amorphous silica that frequently contain crystalline forms.

This product is in granular form and packed in bags for use as a desiccant. Therefore, no exposure to the product is anticipated under normal use of this product. Avoid inhaling desiccant dust.

SECTION III -- PHYSICAL DATA

Appearance and Odor:	White granules; odorless.
Melting Point:	>1600 Deg C; >2900 Deg F
Solubility in Water:	Insoluble.
Bulk Density:	>40 lbs./cu. ft.
Percent Volatile by Weight @ 1750 Deg F:	<10%.

101 Christine Drive
Belen, New Mexico 87002
Phone: (505) 864-6691
Fax: (505) 861-2355



MATERIAL SAFETY DATA SHEET -- September 28, 1998
SORB-IT®
Packaged Desiccant

SECTION IV -- FIRE EXPLOSION DATA

Fire and Explosion Hazard - Negligible fire and explosion hazard when exposed to heat or flame by reaction with incompatible substances.

Flash Point - Nonflammable.

Firefighting Media - Dry chemical, water spray, or foam. For larger fires, use water spray fog or foam.

Firefighting - Nonflammable solids, liquids, or gases: Cool containers that are exposed to flames with water from the side until well after fire is out. For massive fire in enclosed area, use unmanned hose holder or monitor nozzles; if this is impossible, withdraw from area and let fire burn. Withdraw immediately in case of rising sound from venting safety device or any discoloration of the tank due to fire.

SECTION V -- HEALTH HAZARD DATA

Health hazards may arise from inhalation, ingestion, and/or contact with the skin and/or eyes. Ingestion may result in damage to throat and esophagus and/or gastrointestinal disorders. Inhalation may cause burning to the upper respiratory tract and/or temporary or permanent lung damage. Prolonged or repeated contact with the skin, in absence of proper hygiene, may cause dryness, irritation, and/or dermatitis. Contact with eye tissue may result in irritation, burns, or conjunctivitis.

First Aid (Inhalation) - Remove to fresh air immediately. If breathing has stopped, give artificial respiration. Keep affected person warm and at rest. Get medical attention immediately.

First Aid (Ingestion) - If large amounts have been ingested, give emetics to cause vomiting. Stomach siphon may be applied as well. Milk and fatty acids should be avoided. Get medical attention immediately.

First Aid (Eyes) - Wash eyes immediately and carefully for 30 minutes with running water.

[101 Christine Drive](#)
[Belen, New Mexico 87002](#)
[Phone: \(505\) 864-6691](#)
[Fax: \(505\) 861-2355](#)



MATERIAL SAFETY DATA SHEET -- September 28, 1998
SORB-IT®
Packaged Desiccant

NOTE TO PHYSICIAN: This product is a desiccant and generates heat as it adsorbs water. The used product can contain material of hazardous nature. Identify that material and treat accordingly.

SECTION VI -- REACTIVITY DATA

Reactivity - Silica gel is stable under normal temperatures and pressures in sealed containers. Moisture can cause a rise in temperature which may result in a burn.

SECTION VII -- SPILL OR LEAK PROCEDURES

Notify safety personnel of spills or leaks. Clean-up personnel need protection against inhalation of dusts or fumes. Eye protection is required. Vacuuming and/or wet methods of cleanup are preferred. Place in appropriate containers for disposal, keeping airborne particulates at a minimum.

SECTION VIII -- SPECIAL PROTECTION INFORMATION

Respiratory Protection - Provide a NIOSH/MSHA jointly approved respirator in the absence of proper environmental control. Contact your safety equipment supplier for proper mask type.

Ventilation - Provide general and/or local exhaust ventilation to keep exposures below the TLV. Ventilation used must be designed to prevent spots of dust accumulation or recycling of dusts.

Protective Clothing - Wear protective clothing, including long sleeves and gloves, to prevent repeated or prolonged skin contact.

Eye Protection - Chemical splash goggles designed in compliance with OSHA regulations are recommended. Consult your safety equipment supplier.

101 Christine Drive
Belen, New Mexico 87002
Phone: (505) 864-6691
Fax: (505) 861-2355



MATERIAL SAFETY DATA SHEET -- September 28, 1998
SORB-IT®
Packaged Desiccant

SECTION IX -- SPECIAL PRECAUTIONS

Avoid breathing dust and prolonged contact with skin. Silica gel dust causes eye irritation and breathing dust may be harmful.

* No Information Available

HMIS (Hazardous Materials Identification System) for this product is as follows:

Health Hazard	0
Flammability	0
Reactivity	0
Personal Protection	HMIS assigns choice of personal protective equipment to the customer, as the raw material supplier is unfamiliar with the condition of use.

The information contained herein is based upon data considered true and accurate. However, United Desiccants makes no warranties expressed or implied, as to the accuracy or adequacy of the information contained herein or the results to be obtained from the use thereof. This information is offered solely for the user's consideration, investigation and verification. Since the use and conditions of use of this information and the material described herein are not within the control of United Desiccants, United Desiccants assumes no responsibility for injury to the user or third persons. The material described herein is sold only pursuant to United Desiccants' Terms and Conditions of Sale, including those limiting warranties and remedies contained therein. It is the responsibility of the user to determine whether any use of the data and information is in accordance with applicable federal, state or local laws and regulations.

TIENet® 360 LaserFlow Ex® Velocity Sensor

Index

Symbols

.ddp files, C-1

Numerics

2160 Laser Module
 setup, 4-1
360 advanced settings
 2160, 4-8
 Signature, 3-5
360 level
 2160, 4-5
 Signature, 3-5
360 velocity
 2160, 4-7
 flow direction, 3-5
 Signature, 3-5

A

accessories, 1-5

B

beam angle, 2-6
bubble level, 2-22

C

cable connection, 2-7
 2160, 2-13
 Signature, 2-8
character grid
 Signature, 3-2
cleaning
 housing, 5-2
 laser window, 5-5
configure measurements
 Signature, 3-3
contact Teledyne Isco, 3-12

D

data dump, C-1
description, 1-1
design, 1-2
dimensions
 temp mount, 2-15
 wall mount, 2-14, 2-15

E

error codes, C-1
 definitions, C-3

F

firmware updates, 5-2
Flowlink software, 4-1
 data dump files, C-1
 viewing error codes, C-3

H

hardware setup
 Signature, 3-3

I

installation, 2-14
 centering the laser - 2160, 4-14
 centering the laser - Signature, 3-10
 constants, 2-16
 position, 2-16
 requirements, 2-16, 2-17
 wall mounting, 2-18
installation checklist, B-1
installation considerations, 2-6

J

jump to measurements
 2160, 4-4

L

laser on, 3-10, 4-14
laser window
 cleaning, 5-5
 condensation, 5-5
 fouling, 5-5
level - initial setting, 4-13

M

maintenance
 cleaning, 5-2
 firmware, 5-2
 opening the sensor, 5-2
Material Safety Data Sheets, D-1
measurement parameters, 3-1, 4-3
measurement points

- 2160, 4-15
- Signature, 3-10
- measurement setup
 - Signature, 3-4
- MSDS, D-1
- multipoint
 - 2160, 4-15
 - Signature, 3-10

O

- opening the sensor, 5-2
- operating principles, 1-2

P

- parts, 1-5, A-1
 - LaserFlow, A-2

R

- replacement parts, A-1
 - LaserFlow, A-2

S

- safety, 2-1
- scan
 - 2160, 4-1
 - Signature, 3-1
- sensor activation
 - 2160, 4-1
 - Signature, 3-1
- setup
 - 2160 Laser Module, 4-1
 - Signature Flow Meter, 3-1
- Signature Flow Meter
 - setup, 3-1
- smart sensor setup
 - Signature, 3-3
- specifications, 1-3

T

- technical specifications, 1-3
- temporary mounting
 - dimensions, 2-15
- troubleshooting, C-1

U

- ultrasonic level
 - 2160, 4-5
 - beam angle, 2-6
 - Signature, 3-11
- unpacking instructions, 1-6
- update device list, 3-1
- update firmware, 5-2

V

- velocity grid
 - 2160, 4-15

- Signature, 3-9, 3-10
- velocity readings
 - invalid or inconsistent, 5-5

W

- wall mounting, 2-18
 - dimensions, 2-14, 2-15
 - procedure, 2-19
- window cap, 1-6

DECLARATION OF CONFORMITY



Application of Council Directive: 2014/30/EU - The EMC Directive
2014/34/EU - The ATEX Directive
2011/65/EU - The RoHS Directive

Manufacturer's Name: Teledyne Isco, Inc.
Manufacturer's Address: 4700 Superior, Lincoln, Nebraska 68504 USA
Mailing Address: P.O. Box 82531, Lincoln, NE 68501

Equipment Type/Environment: Laboratory Equipment for Light Industrial/Commercial Environments:
The 360 LaserFlow Ex is a flow sensor connecting to a water flow-monitoring instrument. The devices are intended for indoor/outdoor operation in ambient temperature range of -10C to +60C.

Trade Name/Model No: TIENet 360 LaserFlow Ex Sensor
Year of Issue: 2019

Provisions of the Directive fulfilled by the Equipment: Ex ia op is IIB T4 Ga (-10C < Tamb < +60C)
IP68 (self-certified; submerged 9 meters for 72 hours)

Notified Body for EC-Type Examination: UL LLC, 333 Pfingsten Rd, Northbrook, IL 60062 USA

EU-type Examination Certificate: TIENet 360 LaserFlow Ex Sensor: DEMKO 18 ATEX 2105X
Rev. 0 Issued March 11, 2019

Notified Body for Production: UL LLC, 333 Pfingsten Rd, Northbrook, IL 60062 USA

Harmonized Safety Standards: EN60079-0:2012+A11:2013, EN60079-11:2012, EN60079-28:2015

Other Standards and Specifications used: EN61326-1:2013 EMC Requirements for Electrical Equipment for Measurement, Control, and Laboratory Use

EN60529:1992/A2:2013 Degrees of Protection Provided by Enclosure;
Self Certified as IP-68 by submersion in water at 3meters for 72Hrs.

EN55011:2009/A1:2010,
Group1, Class A Radiated Emissions

I, the undersigned, hereby declare that the design of the equipment specified above conforms to the above Directive(s) and Standards as of March 21, 2019.

USA Representative:

Samuel C. Ramey

Director of Engineering

 **TELEDYNE ISCO**

A Teledyne Technologies Company

Teledyne Isco

4700 Superior Street

Lincoln, Nebraska 68504

Phone: (402)-464-0231

FAX: (402)-465-3799

60-4362-110
Rev A

产品中有毒有害物质或元素的名称及含量

Name and amount of Hazardous Substances or Elements in the product

部件名称 Component Name	有毒有害物质或元素 Hazardous Substances or Elements					
	铅 (Pb)	汞 (Hg)	镉 (Cd)	六价铬 (Cr(VI))	多溴联苯 (PBB)	多溴二联苯 (PBDE)
线路板 Circuit Boards	X	O	O	O	O	X
接线 Wiring	O	O	O	O	O	X
内部电缆 Internal Cables	O	O	O	O	O	X
主电源线 Line Cord	O	O	O	O	O	X
直流电机 DC Motor	X	O	O	O	O	X
接头 Connectors	O	O	X	O	O	O
电池 Battery	X	X	X	O	O	O

产品中有毒有害物质或元素的名称及含量：Name and amount of Hazardous Substances or Elements in the product

O: 表示该有毒有害物质在该部件所有均质材料中的含量均在ST/ 标准规定的限量要求以下。

O: Represent the concentration of the hazardous substance in this component's any homogeneous pieces is lower than the ST/ standard limitation.

X: 表示该有毒有害物质至少在该部件的某一均质材料中的含量超出ST/ 标准规定的限量要求。

(企业可在此处，根据实际情况对上表中打“X”的技术原因进行进一步说明。)

X: Represent the concentration of the hazardous substance in this component's at least one homogeneous piece is higher than the ST/ standard limitation.

(Manufacturer may give technical reasons to the "X"marks)

环保使用期由经验确定。

The Environmentally Friendly Use Period (EFUP) was determined through experience.

生产日期被编码在系列号码中。前三位数字为生产年(207 代表 2007 年)。随后的一个字母代表月份：

A 为一月，B 为二月，等等。

The date of Manufacture is in code within the serial number. The first three numbers are the year of manufacture (207 is year 2007) followed by a letter for the month. "A" is January; "B" is February and so on.

